

SPECIFICATIONS

BBS320-SS/MIR-UGGG-RU

CyberChill
precision
refrigeration

Retro Back Bar Heavy Duty 3-Door Chiller

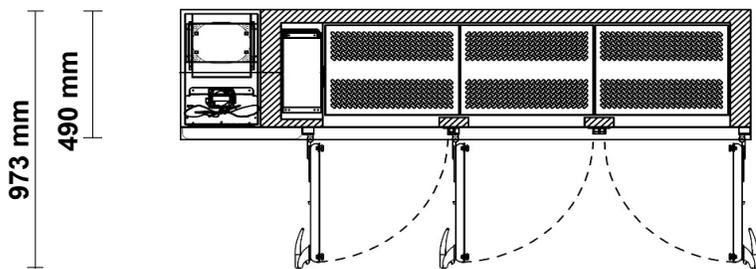
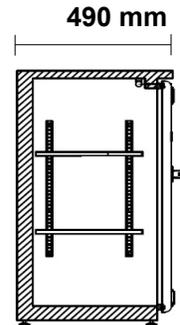
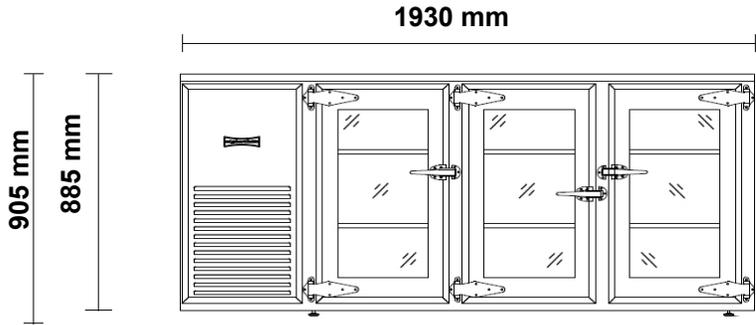

Specifications

Refrigeration system	Self-contained, side mounted, electronically controlled, refrigeration unit		
Refrigerant	R290	Gas Charge	80 g
Electrical	220-240 Volts a.c. 50 Hz	Amps	1.4 Amps
Nominal capacity	373 Watts @ -5°C SST		
Drainage	Waste heat vaporiser located in service compartment (no plumbing required)		
Insulation	50mm thick, high density Zero ODP injected polyurethane insulation		
Cabinet body	304 Stainless Steel Exterior & Mirror Interior, Galvanised Steel Back & Base		
Cabinet temperature range	+3°C to +15°C up to 43°C ambient		
kWh/24hr	n/a	Star Rating	tbc
Cabinet internal volume	270 litres	Net usable GN volume	tbc
Weight	160 kg	dBA	62
Worktop	Integrated 27mm stainless steel worktop		
Door / Drawer	3 x SS Self-Closing Lockable Doors		
Doors / Drawer Configuration	3 x Triple Glazed LowE Argon filled Glass Doors;		
Shelves	2 x SS Perforated shelves & adjustable tray slides per door		Total = 6
Options	Clear or Ribbed Glass Doors, Solid Doors, Painted Exterior, etc.		
Cabinet dimensions	External	Internal	
Width	1930 mm	tbc	
Depth	490 mm	tbc	
Height	885 mm (excl. legs, castors & worktop)		tbc