

SPECIFICATIONS

LPU150-DR

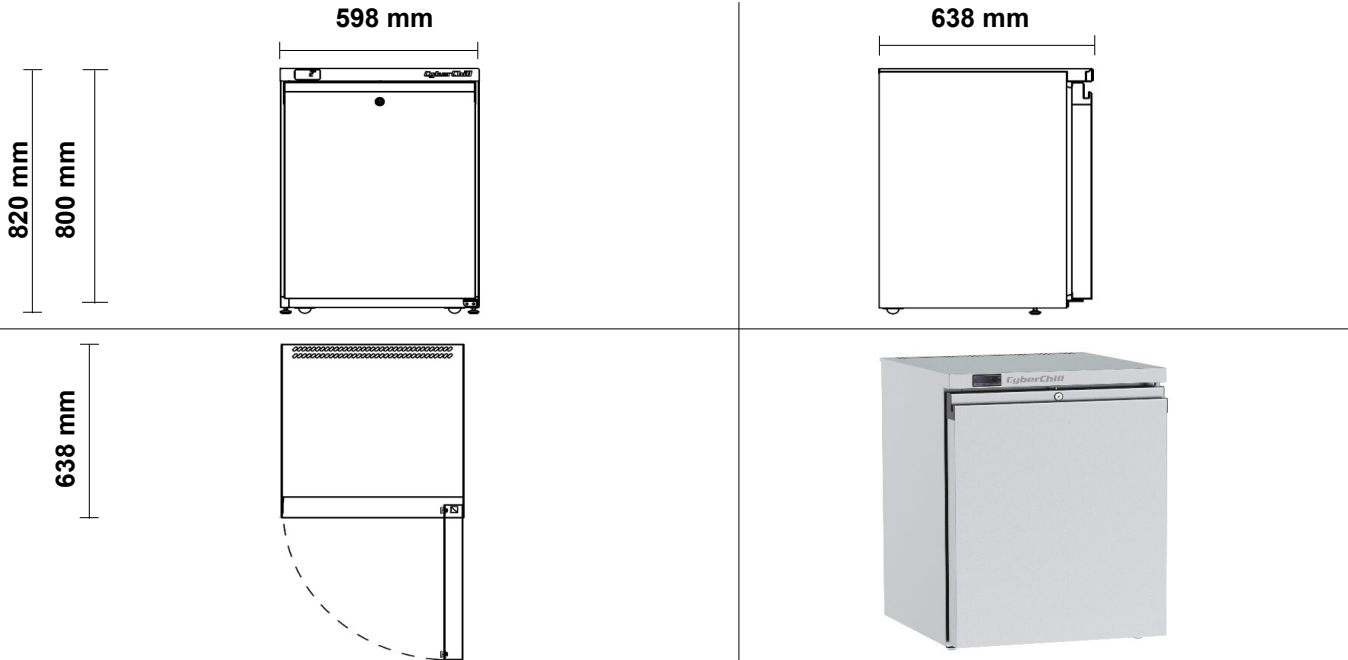

Integral 1-Door Under Counter Freezer



Specifications

Refrigeration system	Self-contained, side mounted, electronically controlled, refrigeration unit		
Refrigerant	R600a	Gas Charge	90 g
Electrical	220-240 Volts a.c. 50 Hz	Amps	1 Amps
Nominal capacity	449 Watts @ -30°C SST		
Drainage	Waste heat vaporiser located in service compartment (no plumbing required)		
Insulation	60mm thick, high density Zero ODP injected polyurethane insulation		
Cabinet body	304 Stainless Steel Interior & Exterior, Galvanised Steel Back & Base		
Cabinet temperature range	-18°C to -22°C up to 32°C ambient		
kWh/24hr	1.77 kWh	Star Rating	tbc
Cabinet internal volume	79 litres	Net usable GN volume	76.7 litres
Weight	62 kg	dBA	53
Worktop	Removable 40mm stainless steel worktop		
Internal Door / Drawer GN Capacity	1 x Door: 2 x Non-Gastronorm Shelves		
Doors / Drawer Configuration	1 x SS Lockable, Self-closing solid door(s)		
Shelves	2 x Fixed Plate Shelves (495mm x 425mm)		Total = 2
Options	Banks of 2/3 Drawers, Glass Doors, Stacking Kits, Legs / Castors		
Cabinet dimensions	External	Internal	
Width	598 mm	495 mm	
Depth	638 mm	379 mm	
Height	800 mm (excl. legs, castors & worktop)		646 mm

Note: Rear mounted compressor. Please ensure cabinet is removable for maintenance. Unit requires 50mm rear ventilation as well as 20mm top and side ventilation.