

SPECIFICATIONS

MCU423-UDDDD

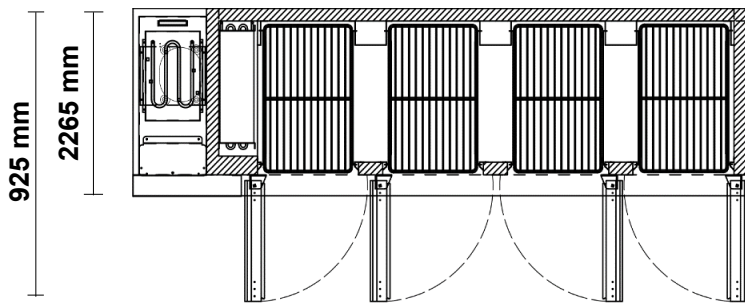

520 Series 4-Door Integral Counter Chiller

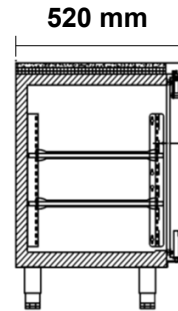
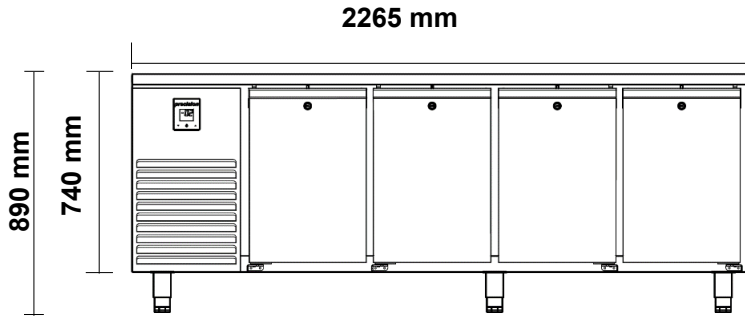

Specifications

Refrigeration system	Self-contained, side mounted, electronically controlled, refrigeration unit		
Refrigerant	R290	Gas Charge	86 g
Electrical	220-240 Volts a.c. 50 Hz	Amps	1.7 Amps
Nominal capacity	383 Watts @ -10°C SST		
Drainage	Waste heat vaporiser located in service compartment (no plumbing required)		
Insulation	60mm thick, high density Zero ODP injected polyurethane insulation		
Cabinet body	304 Stainless Steel Interior & Exterior, Galvanised Steel Back & Base		
Cabinet temperature range	-2°C to +4°C up to 43°C ambient		
kWh/24hr	3.34 kWh	Star Rating	4 Stars
Cabinet internal volume	240 litres	Net usable GN volume	tbc
Weight	185 kg	dBA	62
Worktop	Removable 40mm stainless steel worktop		
Internal Door / Drawer GN Capacity	4 x Door: Accepts full GN2/3 pans		
Doors / Drawer Configuration	4 x SS Lockable, Self-closing SS solid doors		
Shelves	2 x PVC-coated wire shelves & adjustable tray slides per door		Total = 8
Options	Glass Doors, Castors, SS Shelves, LED light, Half or Triple Drawers, etc.		
Cabinet dimensions	External	Internal	
Width	2265 mm	1745 mm	
Depth	520 mm	400 mm	
Height	700 mm (excl. legs, castors & worktop)		600 mm