

SPECIFICATIONS

MCU121-UD

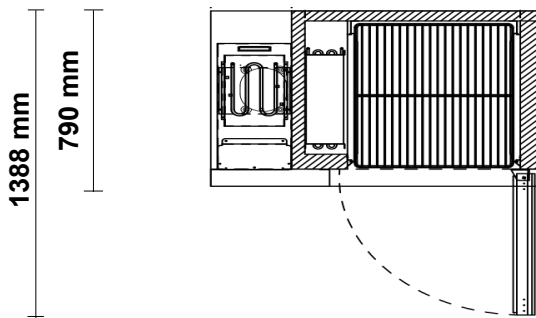

790 Series 1-Door Integral Counter Chiller

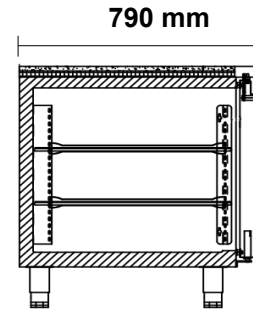
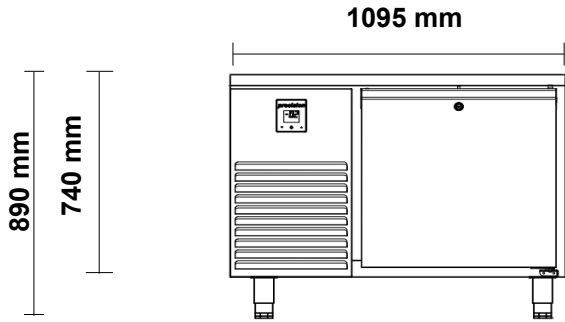

Specifications

Refrigeration system	Self-contained, side mounted, electronically controlled, refrigeration unit		
Refrigerant	R290	Gas Charge	80 g
Electrical	220-240 Volts a.c. 50 Hz	Amps	2 Amps
Nominal capacity	373 Watts @ -10°C SST		
Drainage	Waste heat vaporiser located in service compartment (no plumbing required)		
Insulation	60mm thick, high density Zero ODP injected polyurethane insulation		
Cabinet body	304 Stainless Steel Interior & Exterior, Galvanised Steel Back & Base		
Cabinet temperature range	-2°C to +4°C up to 43°C ambient		
kWh/24hr	tbc	Star Rating	tbc
Cabinet internal volume	230 litres	Net usable GN volume	212 litres
Weight	110 kg	dBa	62
Worktop	Removable 40mm stainless steel worktop		
Internal Door / Drawer GN Capacity	1 x Door: Accepts full GN2/1 pans		
Doors / Drawer Configuration	1 x SS Lockable, Self-closing solid door(s)		
Shelves	2 x PVC-coated wire shelves & adjustable tray slides per door	Total = 2	
Options	Glass Doors, Castors, SS Shelves, LED light, Half or Triple Drawers, etc.		
Cabinet dimensions	External		Internal
	Width	1095 mm	575 mm
	Depth	790 mm	670 mm
	Height	700 mm (excl. legs, castors & worktop)	600 mm