

SPECIFICATIONS

PPC410-DDDD

4-Door Integral Prep Counter Chiller

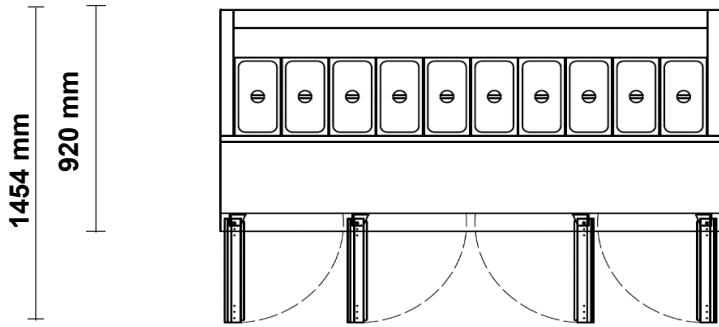
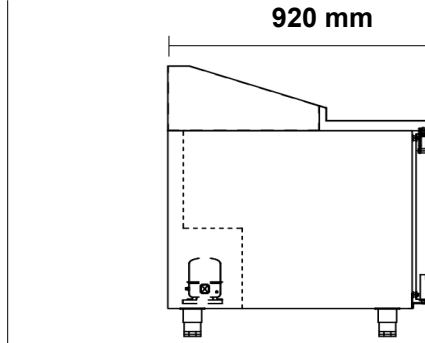
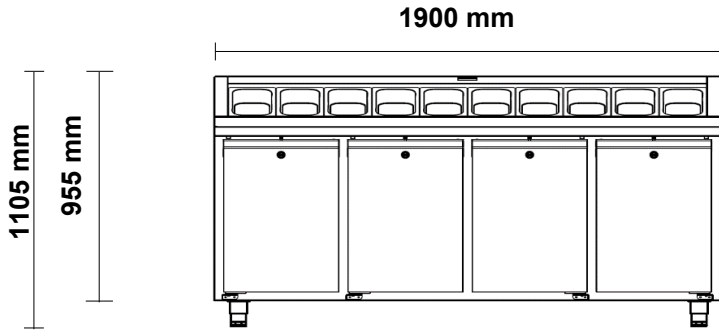

Specifications

Refrigeration system	Self-contained, electronically controlled, refrigeration unit		
Refrigerant	R290	Gas Charge	126 g
Electrical	220-240 Volts a.c. 50 Hz	Amps	tbc
Nominal capacity	572 Watts @ -10°C SST		
Drainage	Waste heat vaporiser located in service compartment (no plumbing required)		
Insulation	60mm thick, high density Zero ODP injected polyurethane insulation		
Cabinet body	304 Stainless Steel Interior & Exterior, Galvanised Steel Back & Base		
Cabinet temperature range	-2°C to +4°C up to 43°C ambient		
kWh/24hr	tbc	Star Rating	tbc
Cabinet internal volume	tbc	Net usable GN volume	tbc
Weight	240 kg	dBA	62
Worktop	Raised Pan Grid to suit 10 x GN1/3 pans (pans not included)		
Internal Door / Drawer GN Capacity	4 x Door: Accepts full GN1/1 pans (325mm wide x 530mm deep)		
Doors / Drawer Configuration	4 x SS Lockable, Self-closing solid door(s)		
Shelves	2 x PVC-coated wire shelves & adjustable tray slides per door	Total = 8	
Options	Doors, Half or Triple Drawers, Airblown Well		
Cabinet dimensions	External	Internal	
Width	1900 mm	1800 mm	
Depth	920 mm	540 mm	
Height	955 mm (excl. legs, castors & worktop)	600 mm	