

# SPECIFICATIONS

## MPU401-FDR

### 1-dr Upright Bottom Mount Chiller

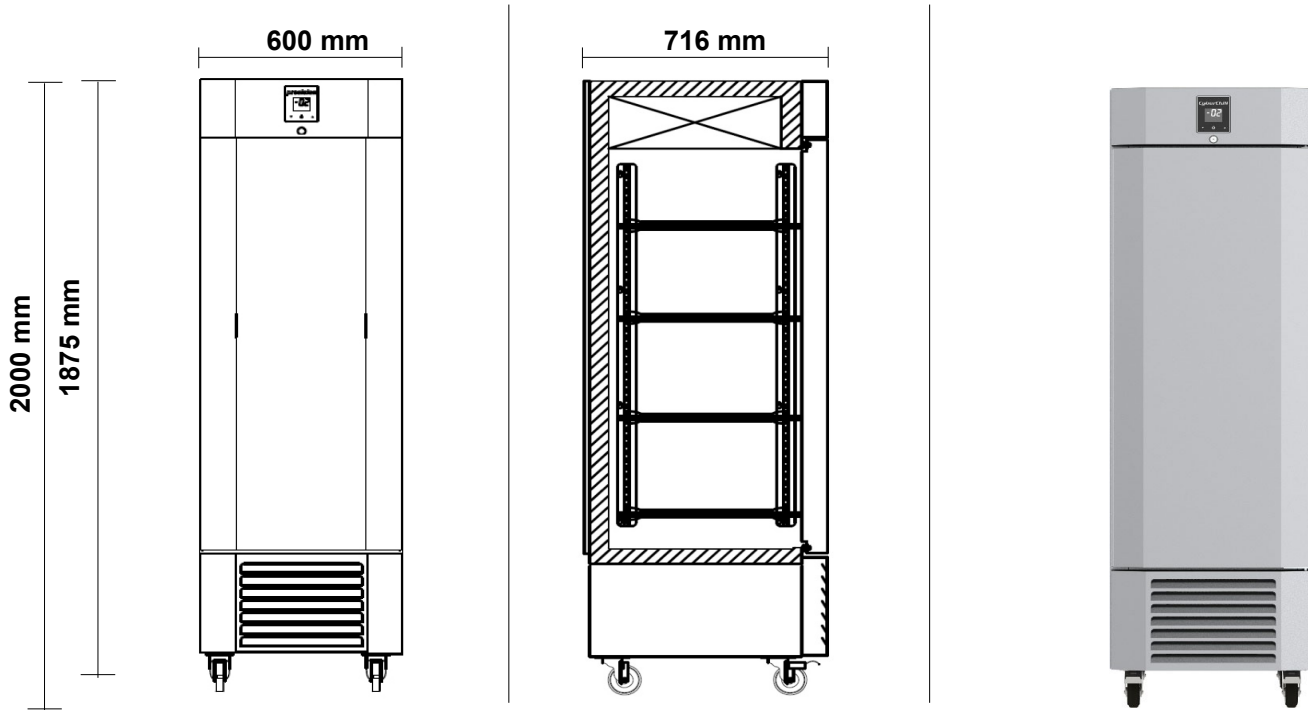

### Specifications

Refrigeration system	Self-contained, bottom mounted, electronically controlled, refrigeration unit		
Refrigerant	R290	Gas Charge	130 g
Electrical	220-240 Volts a.c. 50 Hz	Amps	1.8 Amps
Nominal capacity	373 Watts @ -10°C SST		
Drainage	Waste heat vaporiser located in service compartment (no plumbing required)		
Insulation	90mm thick, high density Zero ODP injected polyurethane insulation		
Cabinet body	304 Stainless Steel Exterior & Interior, Galvanised Steel Back & Base		
Cabinet temperature range	-2°C to +4°C up to 43°C ambient		
kWh/24hr	tbc	Star Rating	tbc
Cabinet internal volume	400 litres	Net usable GN volume	tbc
Weight	110 kg	dB(A)	67
Worktop	n/a		
Door Opening	1 x Self-Closing Lockable Doors (Accepts full GN1/1 pans)		
Door Configuration	1 x Stainless Steel Solid Doors		
Shelves	4 x shelves & adjustable tray slides per door	Total = 4	
Options	Glass Door, Half Doors, Castors/Legs		
Cabinet dimensions	External		Internal
Width	600 mm		490 mm
Depth	716 mm		540 mm
Height	1875 mm (excl. legs or castors)		1294 mm