

SPECIFICATIONS

MCU311-UDDD-AB

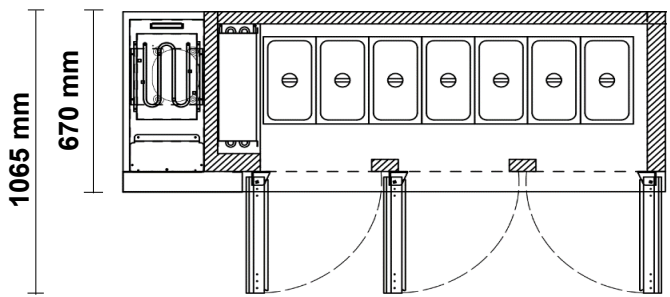

670 Series 3-Door Integral Counter Chiller with Air-Blown Well

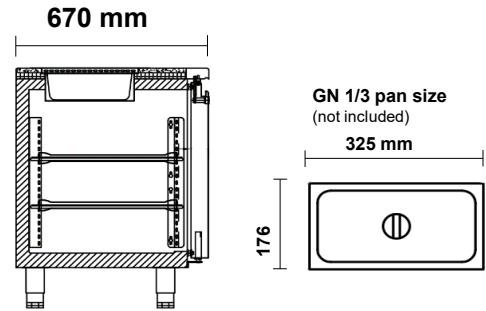
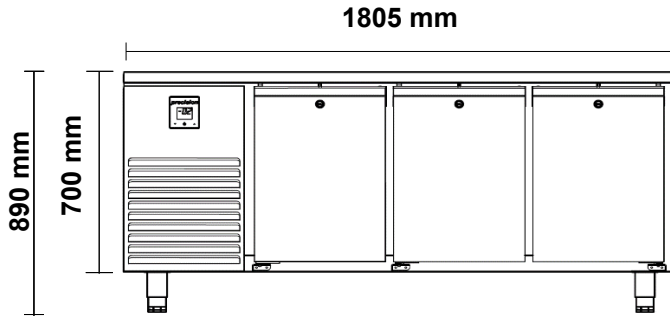

Specifications

Refrigeration system	Self-contained, side mounted, electronically controlled, refrigeration unit		
Refrigerant	R290	Gas Charge	80 g
Electrical	220-240 Volts a.c. 50 Hz	Amps	1.5 Amps
Nominal capacity	373 Watts @ -10°C SST		
Drainage	Waste heat vaporiser located in service compartment (no plumbing required)		
Insulation	60mm thick, high density Zero ODP injected polyurethane insulation		
Cabinet body	304 Stainless Steel Interior & Exterior, Galvanised Steel Back & Base		
Cabinet temperature range	-2°C to +4°C up to 43°C ambient		
kWh/24hr	2.85 kWh	Star Rating	tbc
Cabinet internal volume	450 litres	Net usable GN volume	253 litres
Weight	160 kg	dBA	62
Worktop	Removable 40mm stainless steel worktop ; Airblown well to suit 7 GN1/3 pans (pans not included)		
Internal Door / Drawer GN Capacity	3 x Door: Accepts full GN1/1 pans (325mm wide x 530mm deep)		
Doors / Drawer Configuration	3 x SS Lockable, Self-closing solid door(s)		
Shelves	2 x PVC-coated wire shelves & adjustable tray slides per door	Total = 6	
Options	Glass Doors, Castors, SS Shelves, LED light, Half or Triple Drawers, etc.		
Cabinet dimensions	External	Internal	
Width	1805 mm	1285 mm	
Depth	670 mm	550 mm	
Height	700 mm (excl. legs, castors & worktop)	600 mm	