

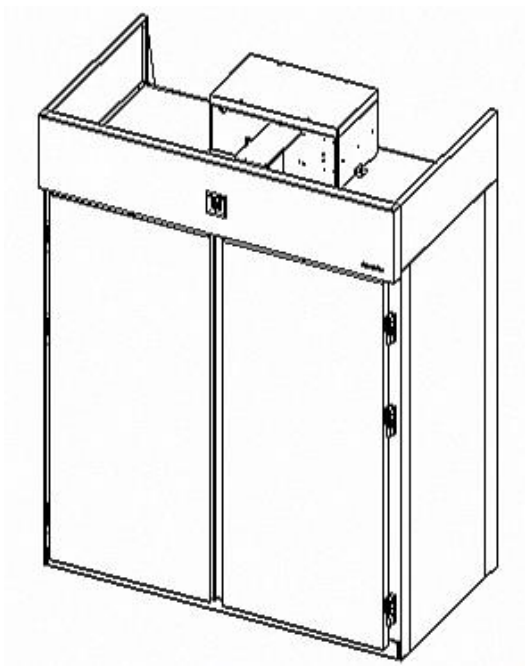

OPERATING INSTRUCTIONS

2 DOOR ROLL-IN REFRIGERATOR

©V1/2015



This page is intentionally left blank.

Contents

General Hazards	3
Electrical connection	3
Unpacking	3-4
Installation	4-13
Ventilation	14
Initial start-up	15
Checks	15-16
Using Your new piece of refrigeration equipment	16
Commissioning instructions	16-17
Defrosting	17-18
Maintenance and cleaning: condenser	18-19
Gasket replacement	19
Disposal requirements	19
Fault finding	20
Alarm	21
Wiring diagram	22
Note	23

All information is subject to change without prior notice

General Hazards

All moving parts of the refrigerator are suitably guarded, any repairs and maintenance should only be carried out by a qualified professional. Any waste or redundant refrigeration devices must be disposed of in accordance with national laws and regulations.

Electrical connection

The product is supplied with a molded plug, which needs a suitable socket. This cabinet should not be used outside and should be used in a dry environment. The plug needs to be accessible once the equipment is placed in its final position. If the plug needs to be replaced, this must be done by qualified staff.



Unpacking

Leave all packaging in place until refrigerator is in its final position to avoid damage. When the cabinet is in its final position, carefully remove all packaging and check for damage. Any damage should be reported immediately to your dealer. All packaging should be carefully disposed of and recycled where possible.

Installation

The roll-in cabinet needs to be installed on site due to its large size. The cabinet is disassembled and marked with numbers before shipping out, customers can conveniently install on site.

Disassembled parts are numbered as in the following diagram:

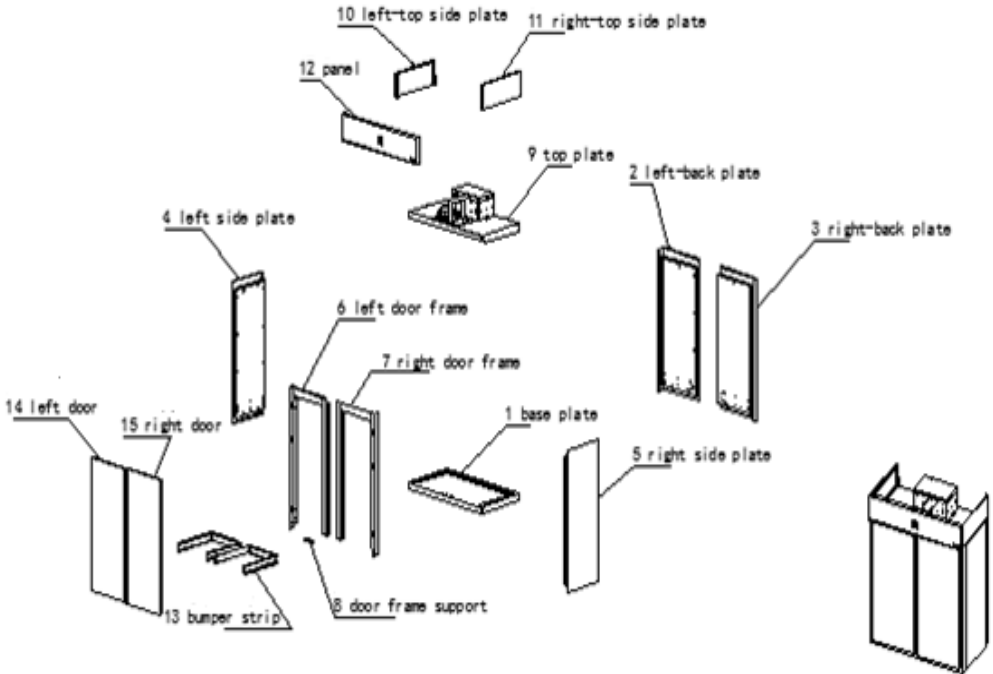

Installation Steps:

1. Fix No.1 base plate to specified location assigned by the site;

1 base plate

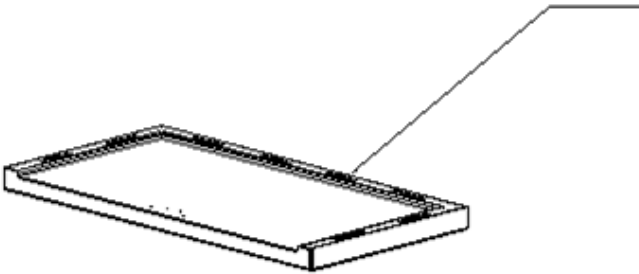

2. Fix No.2 left-backing plate on No.1 base plate, fasten it with hook lock, to ensure a firm connection;

2 left-back palte

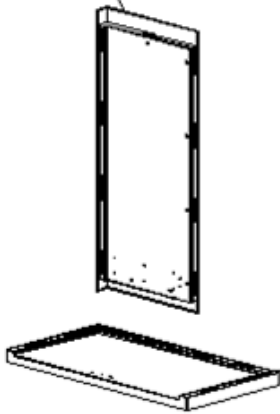

1 base plate

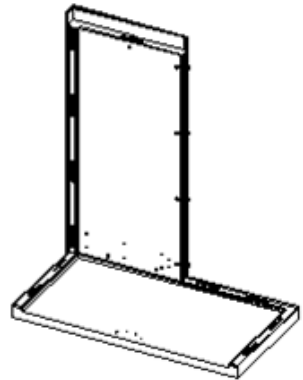

3. Fix No. 3 right-back plate on No. 1 bottom plate and lock it firmly with left back plate and bottom plate by hook lock respectively, to ensure the flat top.

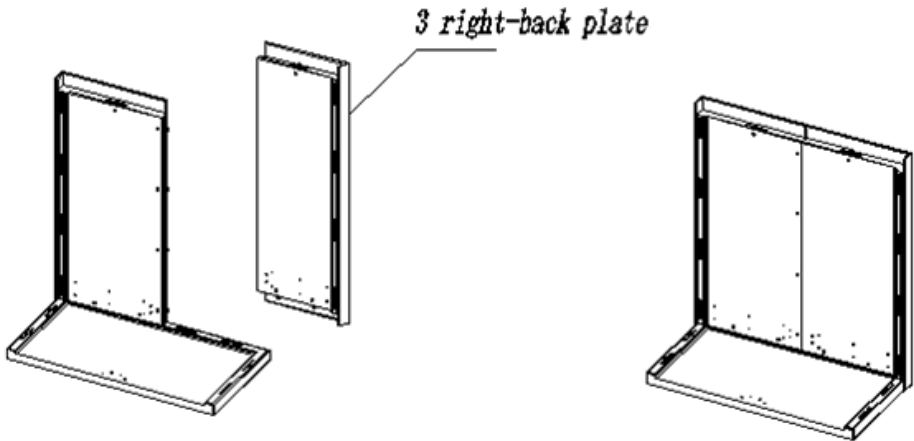

4. Install the left and right side-plates of No. 4 and No. 5 on No. 1 bottom plate respectively, and lock them firmly with the back and bottom plate by hook lock to ensure the flat top.

4 left side plate

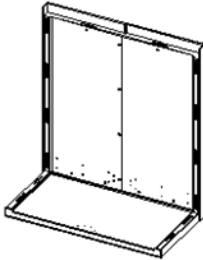

5 right side plate

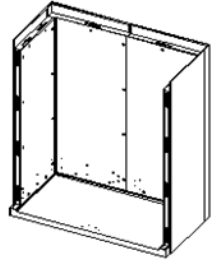

5.1 Connect the door frame wiring heater firmly

5.2 Install the door frame of No. 6 and No. 7 on the side panel, lock the side panel and the door frame by hook lock to ensure the flat top.

5.3 Install the door frame support of No. 8 at the lower part of door frame and fix the center mullion and bottom plate of door frame firmly by M5*10 screw.

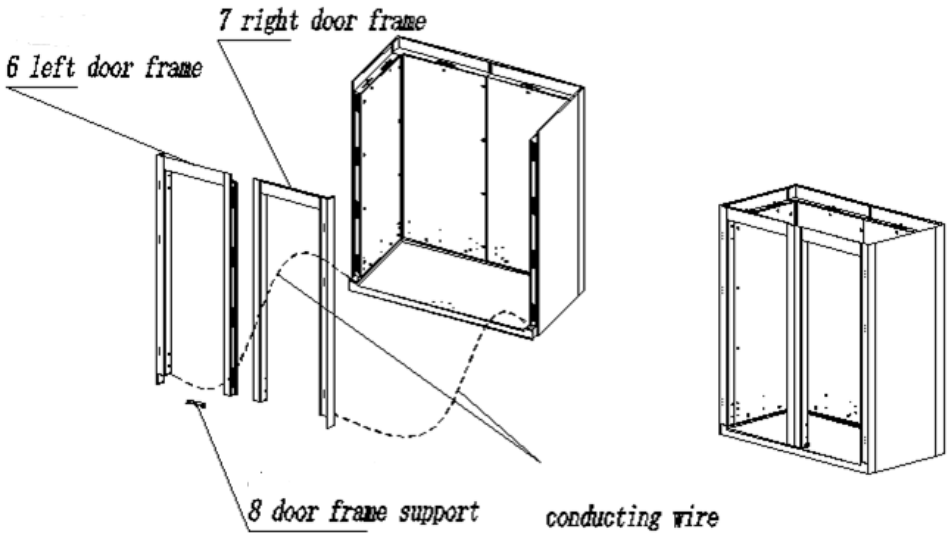

- 6.1 Load the No. 9 top plate together with the connecting unit to the top of cabinet and lock it firmly by hook lock
- 6.2 Connect the door frame wiring heater firmly

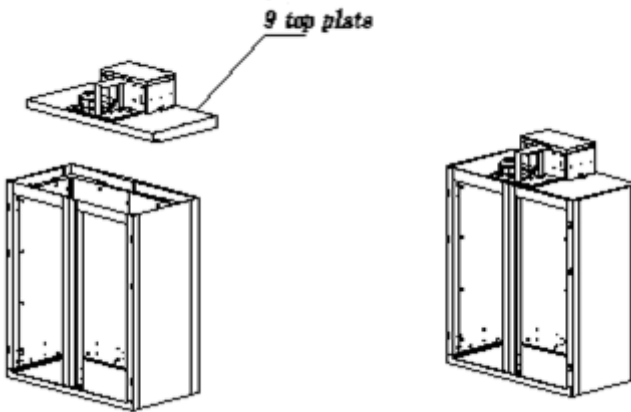

- 7.1 Install No. 10 and No. 11 side plates above the cabinet and connect them firmly by M5*10 screw.
- 7.2 Buckle No. 12 panel on left and right plate
- 7.3 Connect display wire

CyberChill

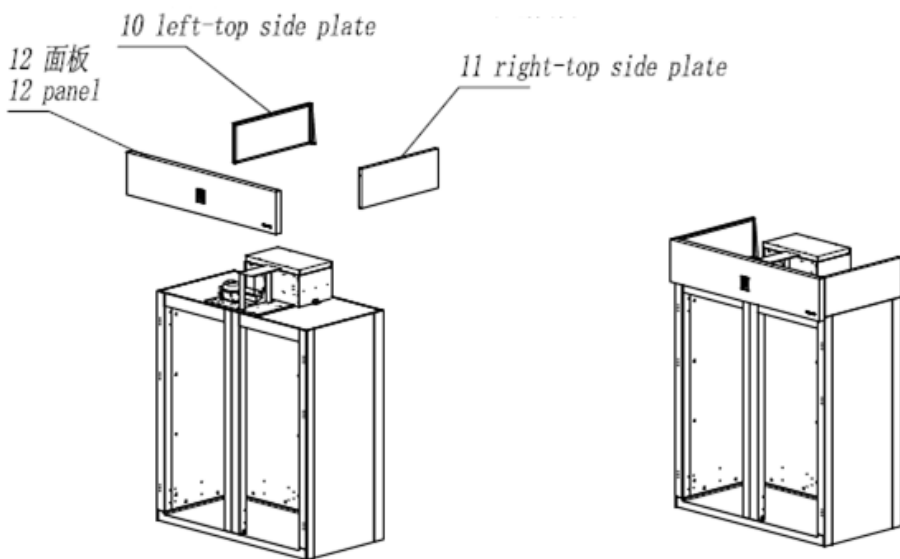

8. Install No. 13 bumper strip into the cabinet liner (bottom) and fasten it firmly by M5*10 screw.

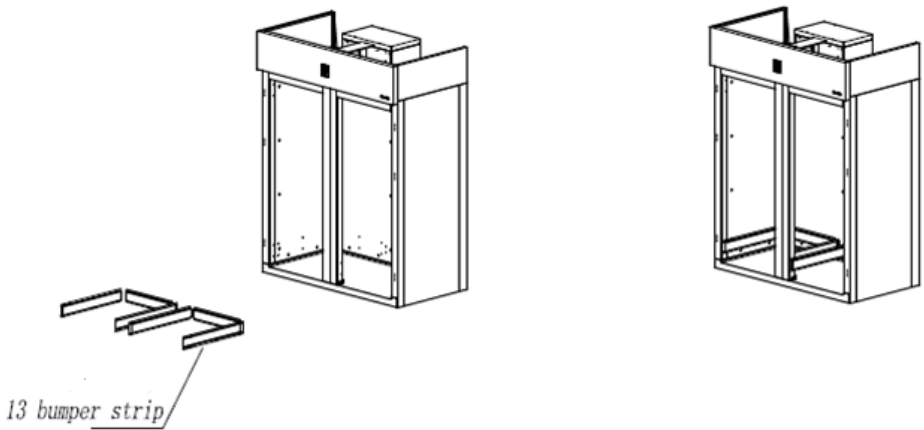

9.1 Hang the left and right doors of No. 14 and No. 15 on the hinge base of door frame, buckle the sealing plate of door hinge base, and the installation is complete.

9.2 Plug in to start up, power supply: 220V/50Hz/2000w

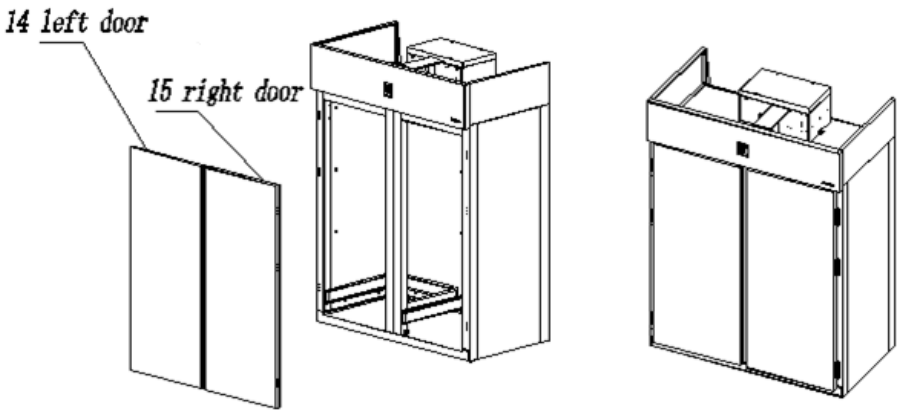

This product must be placed on a horizontal floor to ensure the automatic closure of cabinet doors and proper discharge of condenser water, which is especially important for freezer.

Ventilation

Refrigeration device will generate a lot of heat. Take a 2-door freezer as an example, the heat generated by the refrigerator is equivalent to a 3kw electric heater. Therefore, it is essential that enough space be

provided around the refrigeration unit for ventilation and maintenance access. Ventilation grills must not be blocked, or even partially blocked as this could affect the performance and lifespan of the cabinet.

LAE Electronic Controller Display

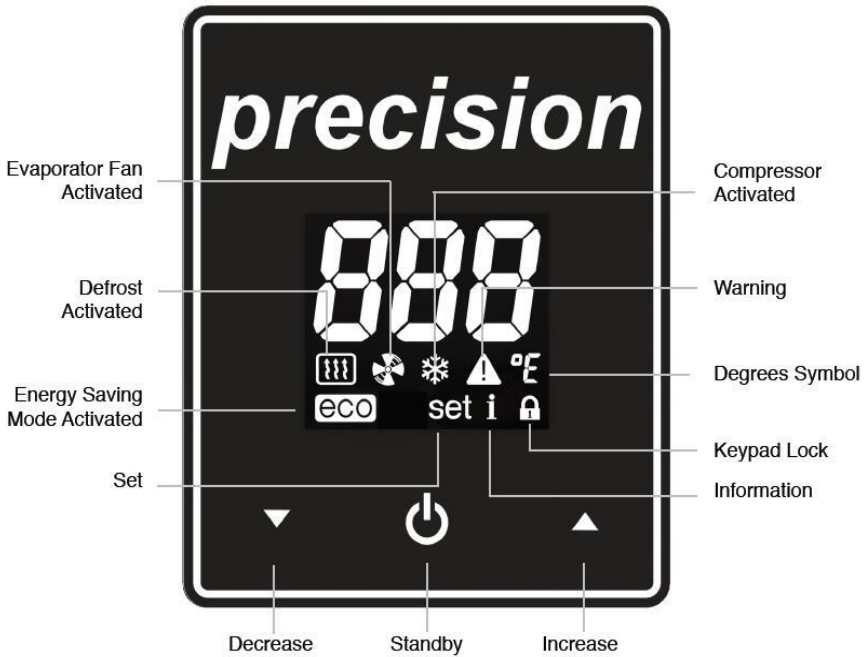

Initial Start Up

Plug the molded plug into a suitable socket. If necessary, push the  button on the controller to start the unit. The cabinet air temperature will be displayed once the unit is running. To standby the unit when running, press and hold the button for 3 seconds.

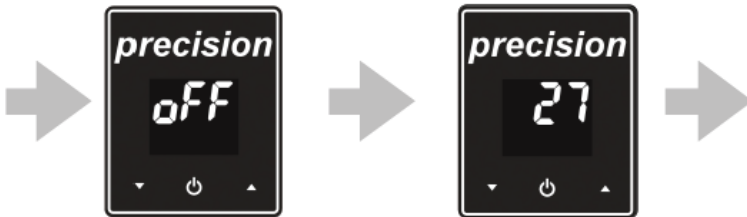

For example: Current temperature

Checks

After initial start-up and a 3-minute time delay the cabinet should start to pull down to the preset temperature. Check that the temperature is reducing and listen inside and outside the cabinet to make sure the fans are turning freely to check there has been no movement in shipping. If time permits, stay with the cabinet until the preset temperature is reached

and the condensing unit cuts out. The preset temperature can be checked by pressing the ▽ and △ button on the controller.

Using Your New Refrigeration Equipment

The cabinet must reach its preset operating temperature before loading any produce. Cover all foods ensuring that cooked and raw foods are kept separate to avoid cross contamination. Warm or hot food should never be stored inside the cabinet. Foods containing acetic acids or yeast should be covered or ideally stored in airtight containers otherwise premature failure of the refrigeration system may occur.

Commissioning Instructions

Refrigerator +1°C to +4°C / freezer -18°C to -22°C

Temperature setting

Refrigerators are designed to operate between +1°C and +4°C depending, freezers between -18°C and -22°C depending.

The controller is preset at the factory for this temperature and should

require no readjustment. The temperature settings can be checked by pressing & holding the ▽ & △ button. The settings then can be changed to better meet the site conditions by pressing ▽ and △ button, and then confirm the changes by pressing ⏻ button.

(The refrigerator can be adjusted to +10°C at the highest and the lowest is +1°C; the freezer can be adjusted to -18°C at the highest and the lowest is -22°C). The temperature set is the cut-out (stopping) temperature; the cut-in (starting) temperature is determined by the differential.

Defrosting

All CyberChill refrigerated cabinets are fitted with a fully automated defrost system that ensures the cooling system remains free from ice under normal conditions. If a manual defrost is required, this can be activated by simultaneously pressing ⏻ & △ buttons, which will terminate automatically once the pre-programmed temperature has been reached.

Maintenance

The cabinet is fully automatic and apart from cleaning needs very little maintenance. Interior and exterior should be cleaned with soap and water and no abrasives should be used as they will scratch and spoil the stainless-steel finish.

Maintenance and Cleaning

Before cleaning and maintenance, the cabinet should be in standby mode then unplugged from the power supply.

Door Gaskets should be cleaned with warm soapy water and inspected on a regular basis, and if damaged they should be replaced. Cooking oils and harsh cleaning detergents will shorten the life of the gaskets and contact should be avoided.

Condenser Cleaning

All the heat removed from the cabinet is discharged into the room via the Condenser, like a car radiator. This must be kept clean so that the air can pass through it to remove the heat, if it becomes choked with dust the unit

will overheat and this can lead to poor cooling performance, increased energy consumption and premature mechanical failure. The condenser should be brushed with a soft brush to remove any dust deposited on the alloy fins. The frequency of this cleaning is determined by the amount of dust in the surrounding area but should be cleaned at least 4 times a year.

Gasket Replacement

Damaged gaskets can easily be replaced. Remove the old gasket by gently pulling it out of the gasket retainer and simply push in the new gasket leaving the corners until last.

End of Life Disposable Requirements

Refrigerated cabinets have components that could be harmful to the environment. All end of life equipment must be disposed of in accordance with national laws and regulations.

Fault Finding

In the event of cabinet fault/failure, please check the following:

1. Plug is in socket and power to the socket can be proven by plugging another appliance into the same socket or swapping the problem cabinet to a socket that is known to work.
2. The fuse located in the plug is intact.
3. The condenser is clean and free from dust or debris.
4. Door gasket is sealing and free from damage.

If this doesn't solve the problem, please call a qualified technician.

When requesting a service call, please find the manufacturer's data plate & provide the model, serial number & details of any fault codes that are displayed.

Alarm

The controller is equipped with audio & visual alarm:

Alarm display	Alarm description	Action required
do	Door Open Alarm	Close door
hC	Condenser High Temperature Alarm	Check for blockage / clean
ALr	High temperature safety alarm	Call engineer
hi	High temperature alarm	Press any button to cancel/check
Lo	Low temperature alarm	Press any button to cancel/check
E1	Probe T1 failure	Call engineer
E2	Probe T2 failure	Call engineer
E3	Probe T3 failure	Call engineer
OFF	Cabinet in standby	Press  button for 3 seconds

Press any button to turn off the alarm.

Wiring diagram:

LAE BD1-28 CONTROLLER WIRING DIAGRAM

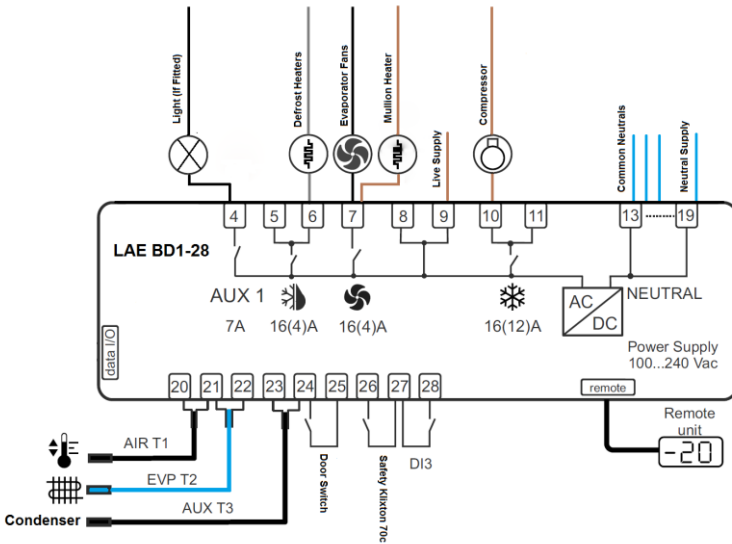

S.G REV:1 17/01/14

Note: Each Roll-in cabinet has two heater wires, one is spare.

Notes: