

# SPECIFICATIONS

## VUBC121

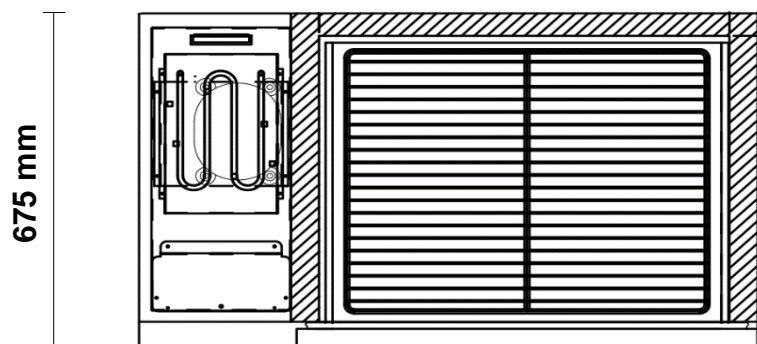

1-drawer - Variable Temp Drawer

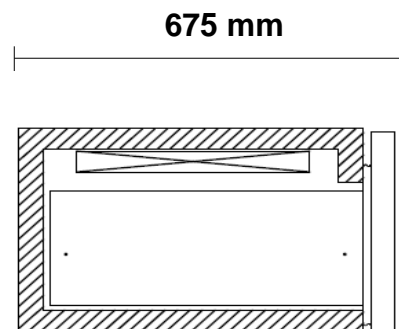
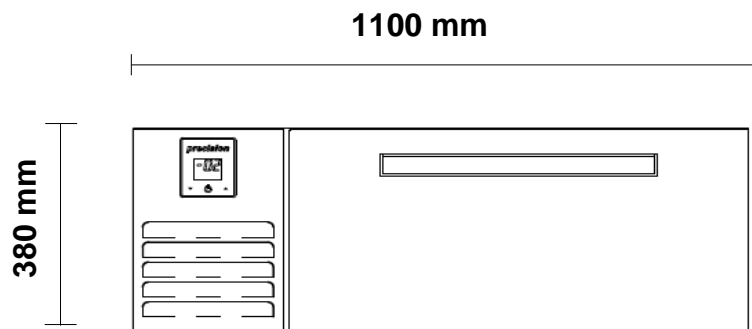

### Specifications

Refrigeration system	Self-contained, side mounted, electronically controlled, refrigeration unit		
Refrigerant	R290	Gas Charge	105 g
Electrical	220-240 Volts a.c. 50 Hz	Amps	1.7 Amps
Nominal capacity	491 Watts @ -10°C SST / 208W @ -30°C SST		
Drainage	Waste heat vaporiser located in service compartment (no plumbing required)		
Insulation	50mm thick, high density Zero ODP injected polyurethane insulation		
Cabinet body	304 Stainless Steel Interior & Exterior, Galvanised Steel Back & Base		
Cabinet temperature range	+1°C to +4°C up to 43°C ambient / -18°C to -22°C up to 43°C ambient		
kWh/24hr	1.6 (C) / 3.8 (F)	Star Rating	tbc
Cabinet internal volume	1 x GN2/1	Net usable GN volume	tbc
Weight	70 kg	dBA	75
Worktop	Excludes Removable 40mm stainless steel worktop		
Internal Door / Drawer GN Capacity	; 1 x Drawer: Accepts 1 x GN2/1 pans		
Doors / Drawer Configuration	; 1 x SS GN2/1 Drawer(s)		
Shelves	2 x PVC-coated wire shelves & adjustable tray slides per door	Total = 0	
Options	Single unit (w/wo worktop/castors) or Stacked units (with worktop/castors)		
Cabinet dimensions	External	Internal	
Width	1100 mm	730 mm	
Depth	675 mm	563 mm	
Height	380 mm (excl. legs, castors & worktop)	202 mm	