

# SPECIFICATIONS

## RBPT601-FDR

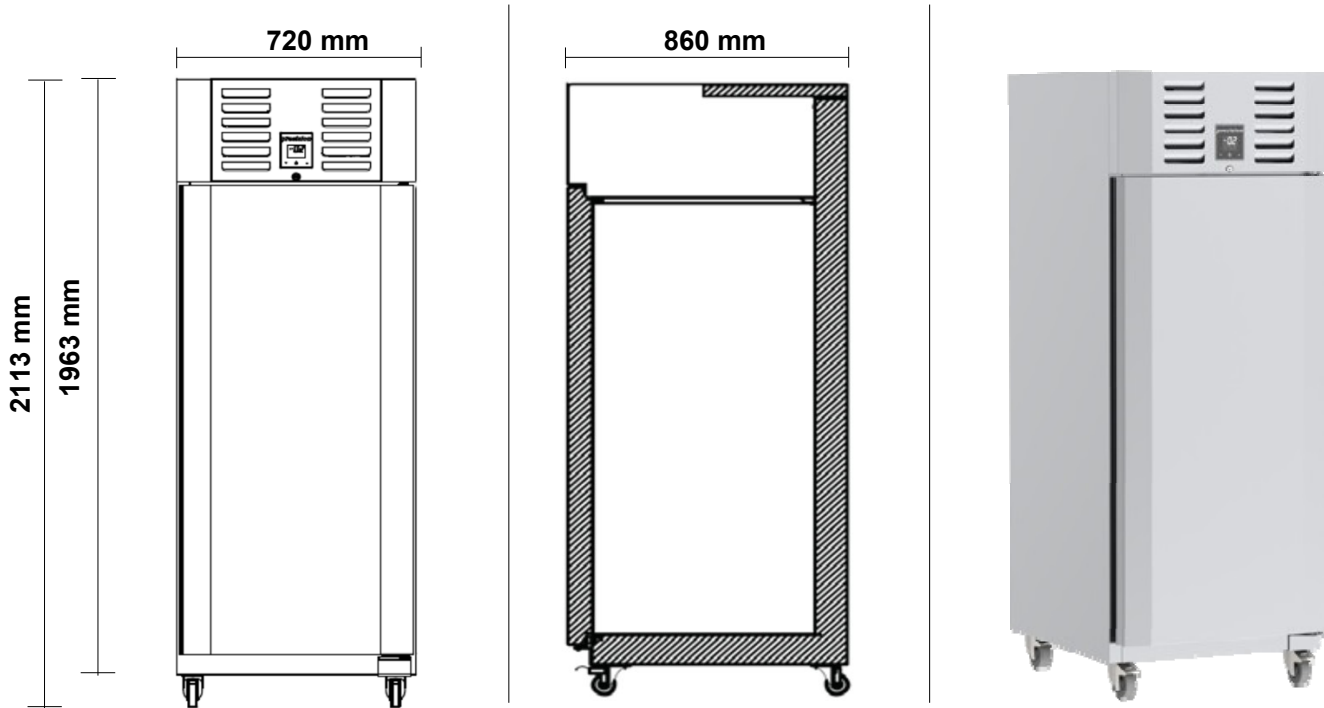

### 1-dr Upright Top Mount Bakery Chiller



### Specifications

Refrigeration system	Self-contained, top mounted, electronically controlled, refrigeration unit		
Refrigerant	R290	Gas Charge	115 g
Electrical	220-240 Volts a.c. 50 Hz	Amps	tbc
Nominal capacity	373 Watts @ -10°C SST		
Drainage	Waste heat vaporiser located in service compartment (no plumbing required)		
Insulation	90mm thick, high density Zero ODP injected polyurethane insulation		
Cabinet body	304 Stainless Steel Exterior & Interior, Galvanised Steel Back & Base		
Cabinet temperature range	-2°C to +4°C up to 43°C ambient		
kWh/24hr	tbc	Star Rating	tbc
Cabinet internal volume	600 litres	Net usable GN volume	tbc
Weight	138 kg	dBa	66
Worktop	n/a		
Door Opening	1 x Door: Accepts full Bakery Tray (400mm wide x 600mm deep)		
Door Configuration	1 x SS Lockable, Self-closing solid door(s)		
Tray Slides	Accepts 10 x Bakery Trays (not included) per door (150mm deep)	Total = 10	
Options	Glass Door, Remote, Legs/Castors		
Cabinet dimensions	External	Internal	
Width	720 mm	557 mm	
Depth	860 mm	657 mm	
Height	1963 mm (excl. legs or castors)	1459 mm	