

SPECIFICATIONS

RBCU264-UDD

Bakery Products 2-Door Counter Chiller

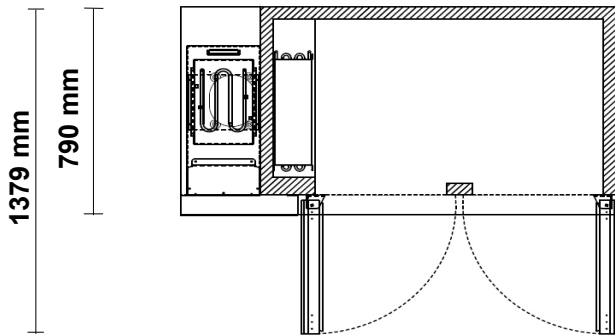
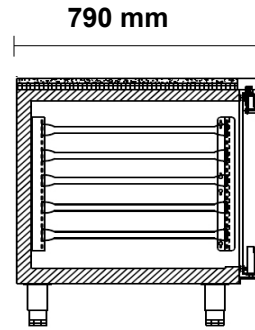
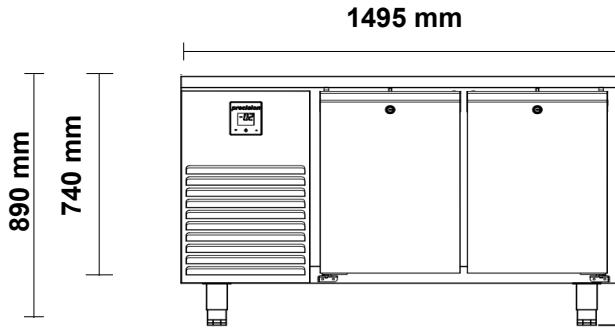

Specifications

Refrigeration system	Self-contained, side mounted, electronically controlled, refrigeration unit		
Refrigerant	R290	Gas Charge	80 g
Electrical	220-240 Volts a.c. 50 Hz	Amps	tbc
Nominal capacity	440 Watts @ -10°C SST		
Drainage	Waste heat vaporiser located in service compartment (no plumbing required)		
Insulation	60mm thick, high density Zero ODP injected polyurethane insulation		
Cabinet body	304 Stainless Steel Interior & Exterior, Galvanised Steel Back & Base		
Cabinet temperature range	-2°C to +4°C up to 43°C ambient		
kWh/24hr	tbc	Star Rating	tbc
Cabinet internal volume	350 litres	Net usable GN volume	tbc
Weight	115 kg	dBa	62
Worktop	Removeable 40mm stainless steel worktop		
Internal Door / Drawer GN Capacity	2 x Door: Accepts full Bakery Tray (400mm wide x 600mm deep)		
Doors / Drawer Configuration	2 x SS Lockable, Self-closing solid door(s)		
Tray Slides	5 x Pairs of tray slides per door	Total = 10	
Options	Stainless Steel Back and Base, Additional Slides		
Cabinet dimensions	External		Internal
	Width	1495 mm	975 mm
	Depth	790 mm	670 mm
	Height	700 mm (excl. legs, castors & worktop)	556 mm