

SPECIFICATIONS

PMR24

1-dr Mobile Banquet Cart (Chiller)

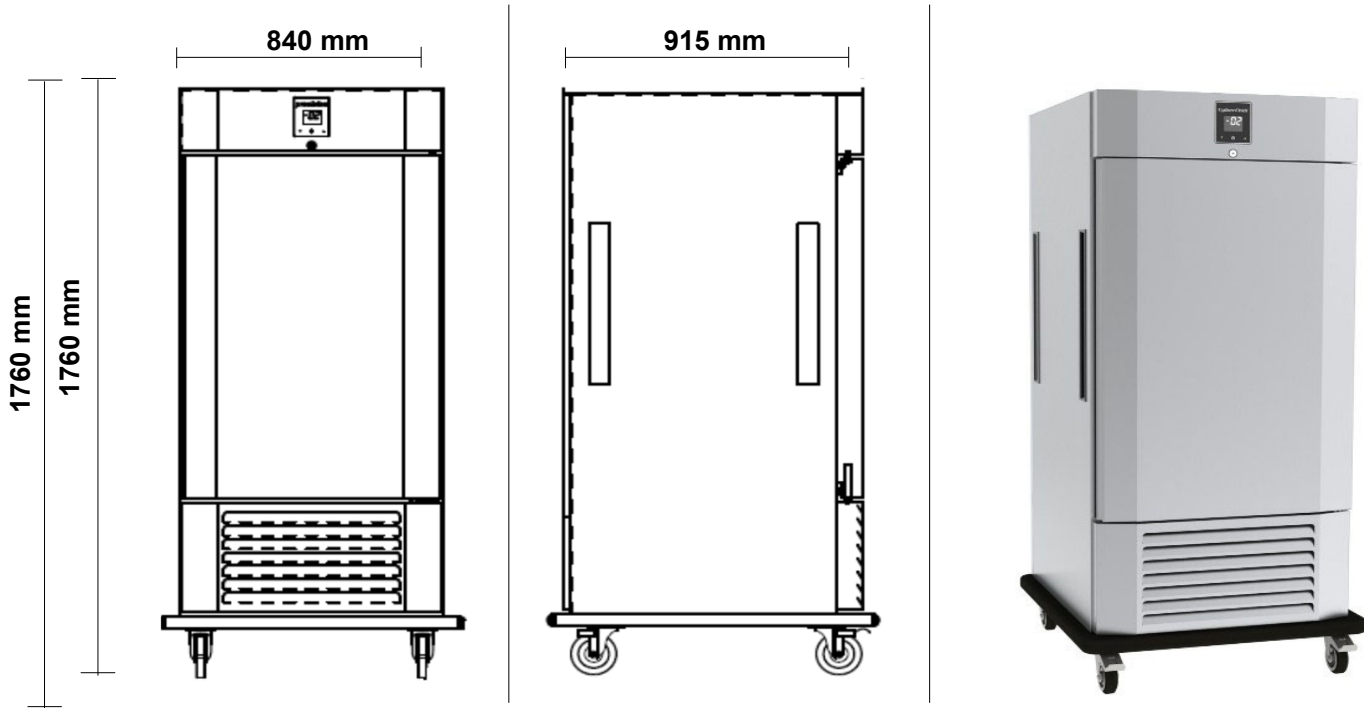

Specifications

Refrigeration system	Self-contained, bottom mounted, electronically controlled, refrigeration unit		
Refrigerant	R290	Gas Charge	115 g
Electrical	220-240 Volts a.c. 50 Hz	Amps	1.7 Amps
Nominal capacity	373 Watts @ -10°C SST		
Drainage	Waste heat vaporiser located in service compartment (no plumbing required)		
Insulation	90mm thick, high density Zero ODP injected polyurethane insulation		
Cabinet body	304 Stainless Steel Exterior & Interior, Galvanised Steel Back & Base		
Cabinet temperature range	-2°C to +4°C up to 43°C ambient		
kWh/24hr	tbc	Star Rating	tbc
Cabinet internal volume	24 x GN1/1 (pans not included)	Net usable GN volume	n/a
Weight	155 kg	dB(A)	tbc
Worktop	n/a		
Door Opening	1 x SS Self-Closing Lockable Doors (Accepts full GN1/1)		
Door Configuration	1 x Stainless Steel Solid Doors		
Shelves	24 x Slides suited to GN1/1 pans	Total = 24	
Options	n/a		
Cabinet dimensions	External		Internal
	Width	840 mm	600 mm
	Depth	915 mm	675 mm
	Height	1760 mm (excl. legs or castors)	1300 mm