

# SPECIFICATIONS

## PMH30

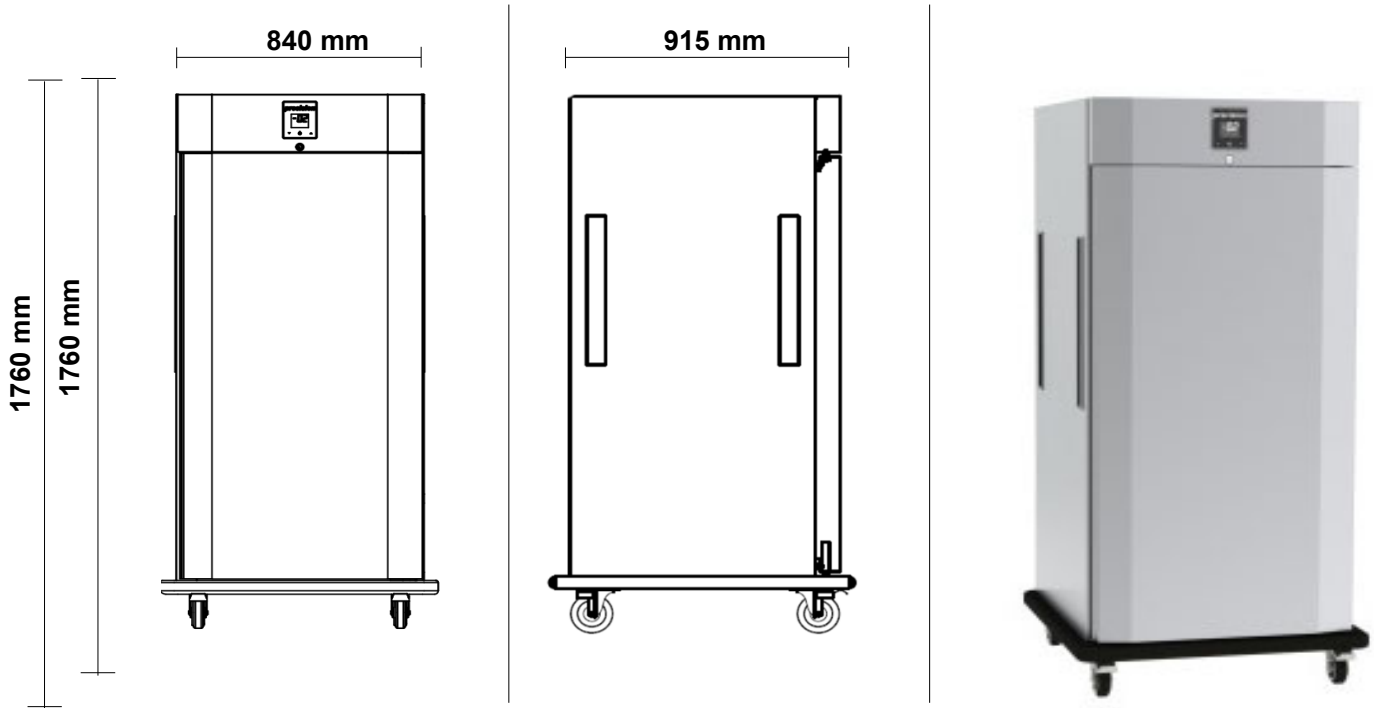

### 1-dr Mobile Banquet Cart (Heated)



### Specifications

Refrigeration system	Self-contained, top mounted, electronically controlled unit		
Refrigerant	n/a	Gas Charge	n/a
Electrical	220-240 Volts a.c. 50 Hz	Amps	9.5 Amps
Nominal capacity	n/a		
Drainage	n/a		
Insulation	60mm thick, high density Zero ODP injected polyurethane insulation		
Cabinet body	304 Stainless Steel Exterior & Interior, Galvanised Steel Back & Base		
Cabinet temperature range	+78°C to +82°C up to 43°C ambient		
kWh/24hr	n/a	Star Rating	tbc
Cabinet internal volume	30 x GN1/1 (pans not included)	Net usable GN volume	n/a
Weight	135 kg	dBa	tbc
Worktop	n/a		
Door Opening	1 x SS Self-Closing Lockable Doors (Accepts full GN1/1)		
Door Configuration	1 x Stainless Steel Solid Doors		
Shelves	30 x Slides suited to GN1/1 pans	Total = 30	
Options	n/a		
Cabinet dimensions	External	Internal	
Width	840 mm	600 mm	
Depth	915 mm	675 mm	
Height	1760 mm (excl. legs or castors)	1300 mm	