

# SPECIFICATIONS

## PCF15

### Blast Chiller/Freezer

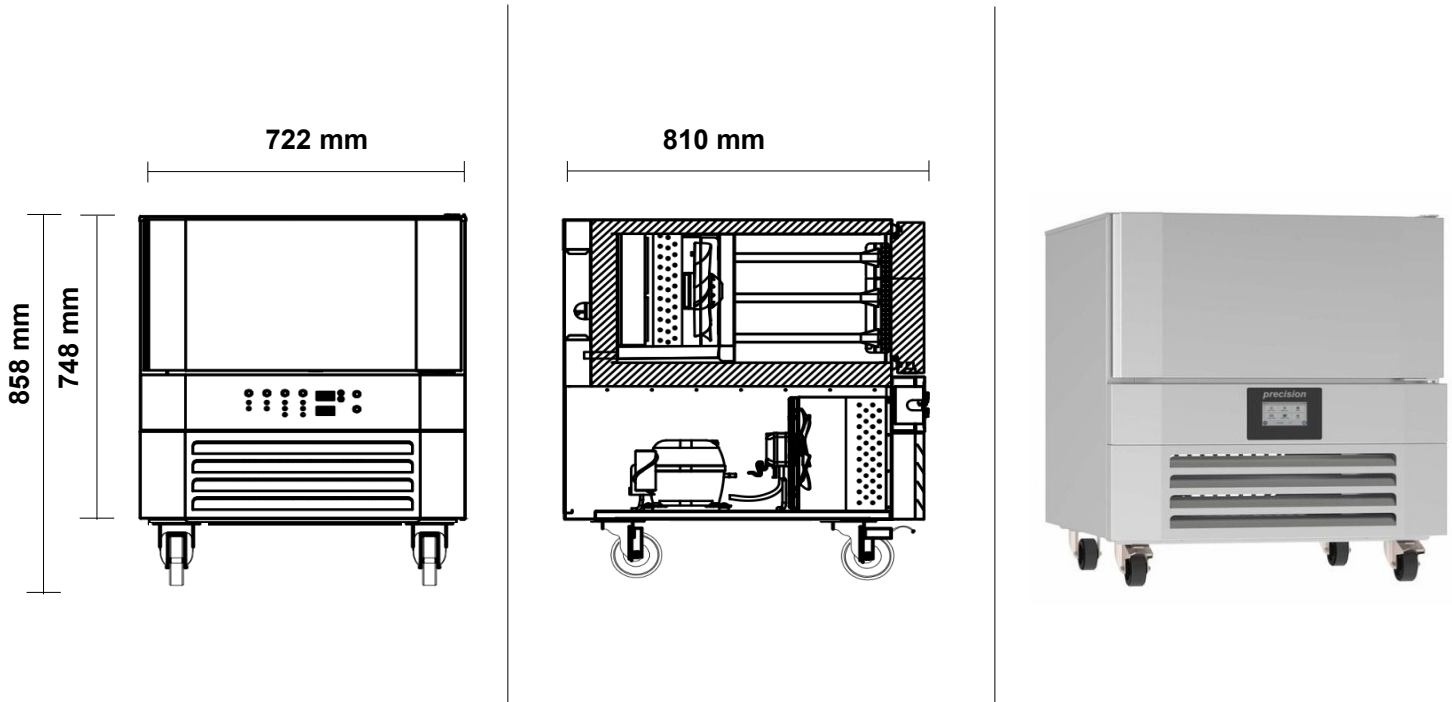

### Specifications

Refrigeration system	Self-contained, bottom mounted, electronically controlled, refrigeration unit		
Refrigerant	R404a	Gas Charge	800 g
Electrical	220-240 Volts a.c. 50 Hz	Amps	6.6 Amps
Nominal capacity	1679 Watts @ -5°C/-25°C SST		
Drainage	Waste heat vaporiser located in service compartment (no plumbing required)		
Insulation	60mm thick, high density Zero ODP injected polyurethane insulation		
Cabinet body	304 Stainless Steel Exterior & Interior, Galvanised Steel Back & Base		
Cabinet temperature range	+90°C to +3°C (90 mins)   +90°C to -18°C (240 mins) up to 43°C ambient		
kWh/24hr	n/a	Star Rating	n/a
Cabinet capacity	15 kg	Net usable GN volume	n/a
Weight	85 kg	dB(A)	tbc
Worktop	n/a		
Door Opening	1 x SS Self-Closing Lockable Doors (Accepts full GN1/1 pans)		
Door Configuration	1 x Stainless Steel Solid Doors		
Shelves	3 x tray slides per door	Total = 3	
Options	n/a		
Cabinet dimensions	External		Internal
	Width	722 mm	600 mm
	Depth	810 mm	350 mm
	Height	748 mm (excl. legs or castors)	320 mm