

# SPECIFICATIONS

## MPU600-FDR

### 1-dr Upright Bottom Mount Chiller

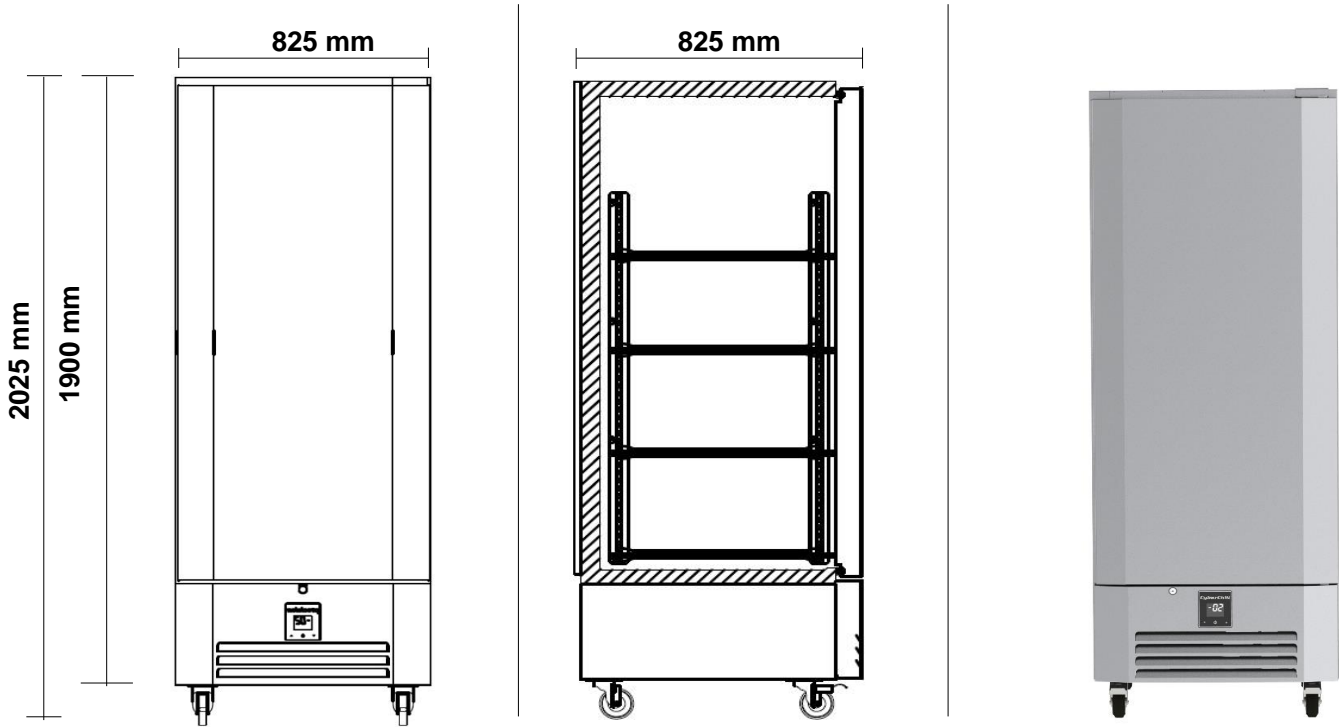

### Specifications

|                           |   |                      |          |
|---------------------------|---|----------------------|----------|
| Refrigeration system      | Self-contained, bottom mounted, electronically controlled, refrigeration unit |                      |          |
| Refrigerant               | R290  | Gas Charge           | 115 g    |
| Electrical                | 220-240 Volts a.c. 50 Hz  | Amps                 | 1.7 Amps |
| Nominal capacity          | 373 Watts @ -10°C SST   |                      |          |
| Drainage                  | Waste heat vaporiser located in service compartment (no plumbing required)    |                      |          |
| Insulation                | 90mm thick, high density Zero ODP injected polyurethane insulation            |                      |          |
| Cabinet body              | 304 Stainless Steel Exterior & Interior, Galvanised Steel Back & Base         |                      |          |
| Cabinet temperature range | -2°C to +4°C up to 43°C ambient   |                      |          |
| kWh/24hr                  | tbc   | Star Rating          | tbc      |
| Cabinet internal volume   | 600 litres  | Net usable GN volume | tbc      |
| Weight                    | 128 kg  | dBa                  | 67       |
| Worktop                   | n/a   |                      |          |
| Door Opening              | 1 x SS Self-Closing Lockable Doors (Accepts full GN1/1 & GN1/2 pans)          |                      |          |
| Door Configuration        | 1 x Stainless Steel Solid Doors   |                      |          |
| Shelves                   | 4 x shelves & adjustable tray slides per door                                 | Total = 4            |          |
| Options                   | Glass Door, Half Doors, Castors/Legs  |                      |          |
| Cabinet dimensions        | External  | Internal             |          |
| Width                     | 720 mm  | 600 mm               |          |
| Depth                     | 825 mm  | 675 mm               |          |
| Height                    | 1900 mm (excl. legs or castors)   | 1480 mm              |          |