

SPECIFICATIONS

MCU121-PC-UD

790 Series 1-Door Integral Counter Chiller with Raised Pan Grid

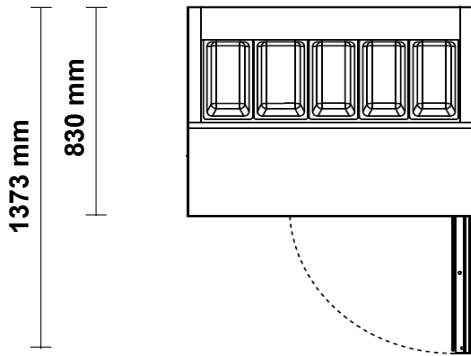
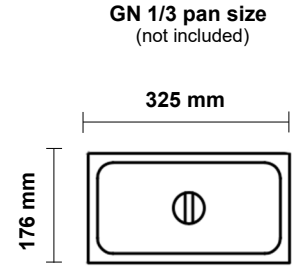
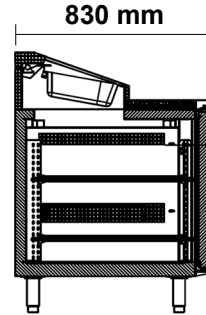
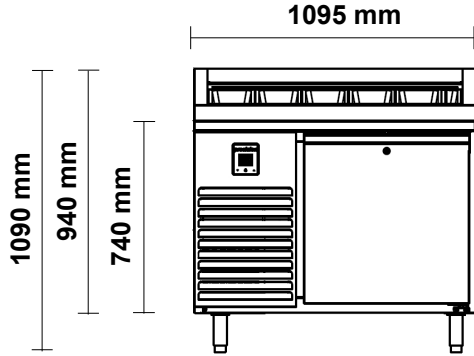

SPECIFICATIONS

Refrigeration system	Electronic controlled, self-contained, side mounted, refrigeration unit	
Refrigerant	R290 / 80g	
Nominal capacity	370 Watts @ -10°C SST	
Cabinet internal volume	213 litres	
Insulation	60mm thick, high density Zero ODP injected polyurethane insulation	
Cabinet temperature range	+1°C to +4°C up to 32°C ambient	
Drainage	Waste heat vaporiser located in service compartment (no plumbing required)	
Electrical	220-240 Volts a.c. 50 Hz, 2.5 Amps	
kWh/24hr	N/a	
Internal door opening size	1 door opening, accepts full 2/1 GN pans (650mm wide x 530mm deep)	
Doors	Stainless steel, self-closing, lockable solid doors	
Worktop	Integrated stainless steel worktop, with Raised-Pan Grid, accepts 5 x 1/3GN pans (to suit 100mm D pans)	
Shelves	2 shelves & adjustable tray slides per door (Total 2)	
Weight	115kg	
Cabinet dimensions	External	Internal
Width	1095mm	575mm
Depth	830mm	710mm
Height	700mm*	600mm

OPTIONS

- Glass Doors
- Bank of 2 Drawers
- Bank of 3 Drawers
- Remote Units
- Castors/Adjustable Feet (Standard on 150mm legs)
- Splashbacks
- Extended Worktops
- No Worktop
- Different Heights
- Countertop Well
- Over-shelf / Gantry
- Water-cooled
- Extra Shelves
- Extra Slides
- ST/ST Back
- Heli-coil Cable
- Hydrocarbon Refrigerant
- HFO Refrigerant

* Height excludes castors, legs or SS worktop