

SPECIFICATIONS

LPT601-FDR

1-dr Upright Top Mount Freezer

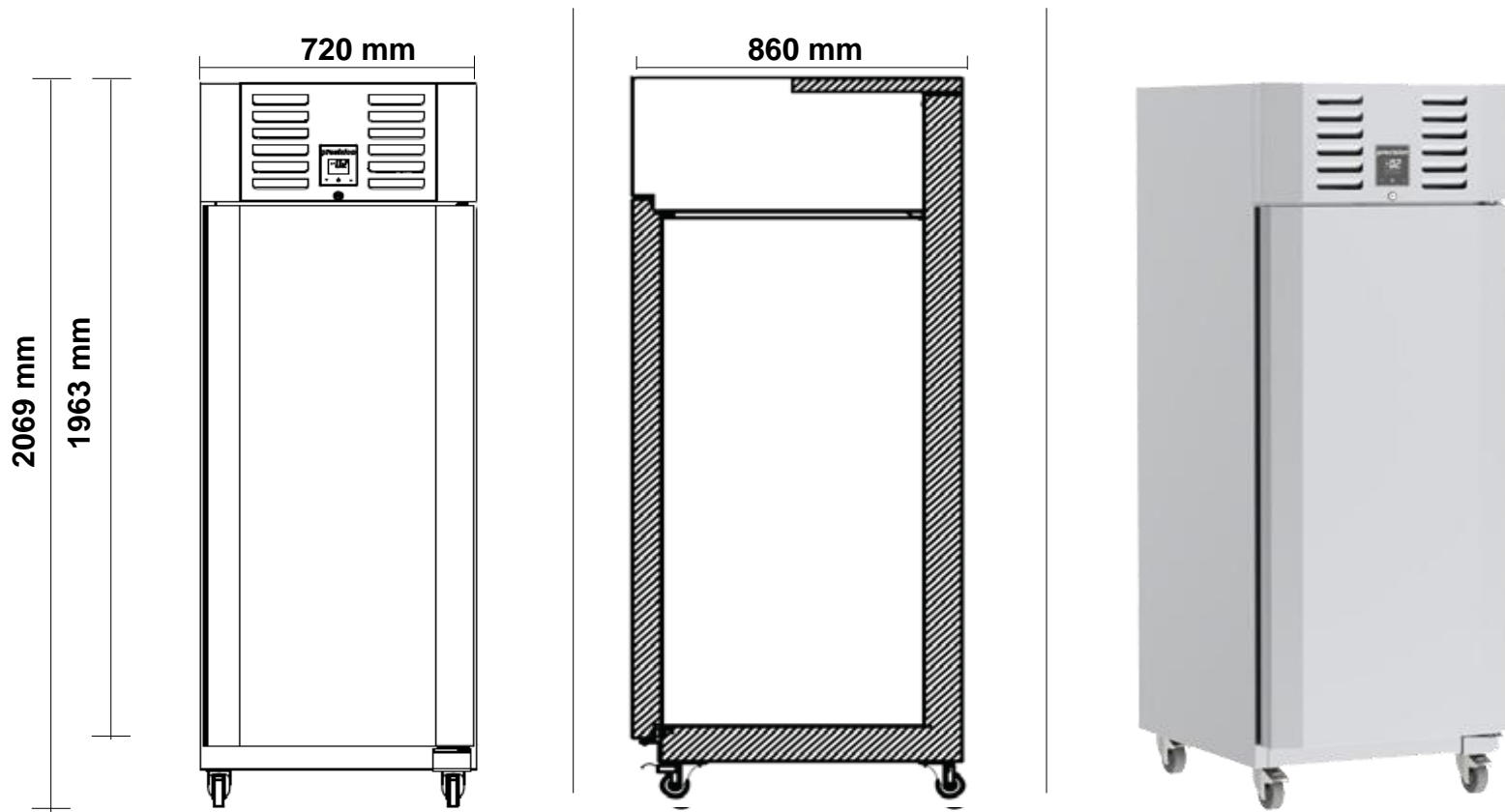

Specifications

Refrigeration system	Self-contained, top mounted, electronically controlled, refrigeration unit		
Refrigerant	R290	Gas Charge	110 g
Electrical	220-240 Volts a.c. 50 Hz	Amps	3.5 Amps
Nominal capacity	449 Watts @ -30°C SST		
Drainage	Waste heat vaporiser located in service compartment (no plumbing required)		
Insulation	90mm thick, high density Zero ODP injected polyurethane insulation		
Cabinet body	304 Stainless Steel Exterior & Interior, Galvanised Steel Back & Base		
Cabinet temperature range	-18°C to -22°C up to 43°C ambient		
kWh/24hr	tbc	Star Rating	tbc
Cabinet internal volume	600 litres	Net usable GN volume	tbc
Weight	146 kg	dBA	69
Worktop	n/a		
Door Opening	1 x SS Self-Closing Lockable Doors (Accepts full GN1/1 & GN1/2 pans)		
Door Configuration	1 x Stainless Steel Solid Doors		
Shelves	4 x shelves & adjustable tray slides per door		Total = 4
Options	Glass Door, Remote, Legs/Castors		
Cabinet dimensions	External	Internal	
Width	720 mm	557 mm	
Depth	860 mm	657 mm	
Height	1963 mm (excl. legs or castors)	1459 mm	