

# SPECIFICATIONS

## LCU211-UDD

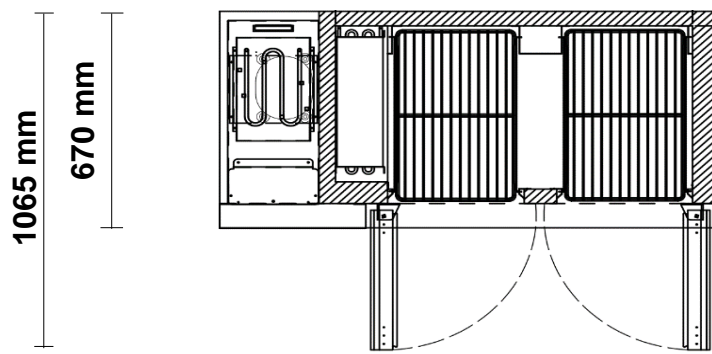

### 670 Series 2-Door Integral Counter Freezer

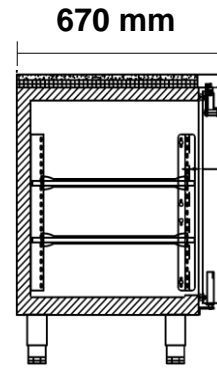
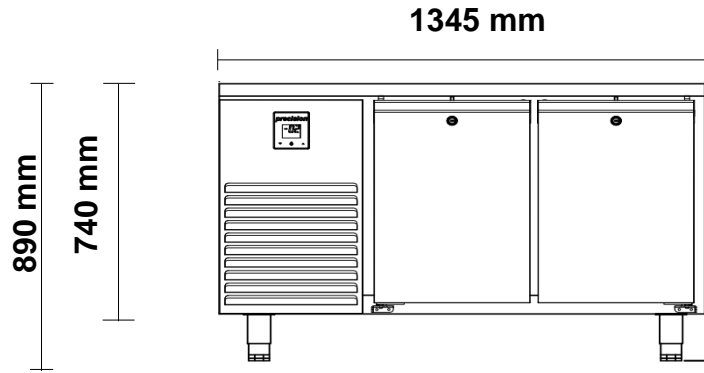

### Specifications

Refrigeration system	Self-contained, side mounted, electronically controlled, refrigeration unit		
Refrigerant	R290	Gas Charge	90 g
Electrical	220-240 Volts a.c. 50 Hz	Amps	3 Amps
Nominal capacity	449 Watts @ -30°C SST		
Drainage	Waste heat vaporiser located in service compartment (no plumbing required)		
Insulation	60mm thick, high density Zero ODP injected polyurethane insulation		
Cabinet body	304 Stainless Steel Interior & Exterior, Galvanised Steel Back & Base		
Cabinet temperature range	-18°C to -22°C up to 43°C ambient		
kWh/24hr	8.49 kWh	Star Rating	tbc
Cabinet internal volume	300 litres	Net usable GN volume	168 litres
Weight	130 kg	dBA	63
Worktop	Removable 40mm stainless steel worktop		
Internal Door / Drawer GN Capacity	2 x Door: Accepts full GN1/1 pans (325mm wide x 530mm deep)		
Doors / Drawer Configuration	2 x SS Lockable, Self-closing SS solid doors		
Shelves	2 x PVC-coated wire shelves & adjustable tray slides per door	Total = 4	
Options	Glass Doors, Castors, SS Shelves, LED light, Half or Triple Drawers, etc.		
Cabinet dimensions	External	Internal	
Width	1345 mm	825 mm	
Depth	670 mm	550 mm	
Height	700 mm (excl. legs, castors & worktop)	600 mm	