

SPECIFICATIONS

HUBC211-HU

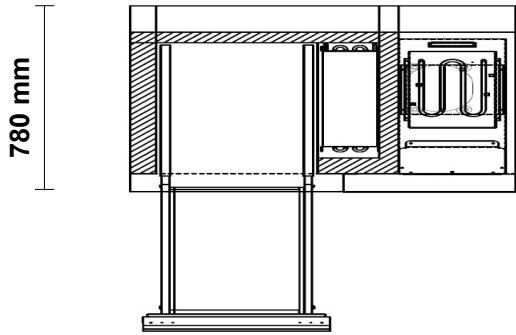

2-Drawer Under Broiler Counter Chiller

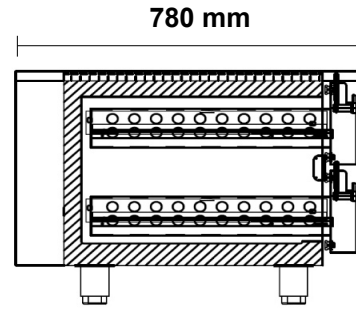
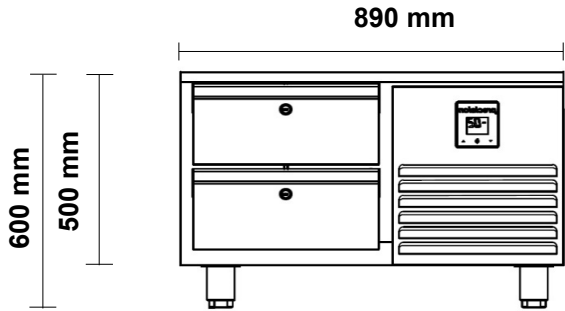

Specifications

Refrigeration system	Self-contained, side mounted, electronically controlled, refrigeration unit		
Refrigerant	R290	Gas Charge	80 g
Electrical	220-240 Volts a.c. 50 Hz	Amps	1.9 Amps
Nominal capacity	373 Watts @ -10°C SST		
Drainage	Waste heat vaporiser located in service compartment (no plumbing required)		
Insulation	60mm thick, high density Zero ODP injected polyurethane insulation		
Cabinet body	304 Stainless Steel Interior & Exterior, Galvanised Steel Back & Base		
Cabinet temperature range	+1°C to +4°C up to 43°C ambient		
kWh/24hr	tbc	Star Rating	tbc
Cabinet internal volume	n/a	Net usable GN volume	tbc
Weight	100 kg	dBa	62
Worktop	25mm Heat Resistant Stainless Steel Worktop		
Internal Door / Drawer GN Capacity	2 x GN1/1 Drawer(s) [325mm x 530mm]		
Doors / Drawer Configuration	2 x SS Lockable GN1/1 Drawers		
Shelves	n/a	Total = 0	
Options	Castors or Legs, LH Unit		
Cabinet dimensions	External		Internal
	Width	890 mm	365 mm
	Depth	780 mm	550 mm
	Height	500 mm (excl. legs, castors)	375 mm