

SPECIFICATIONS

HPU152

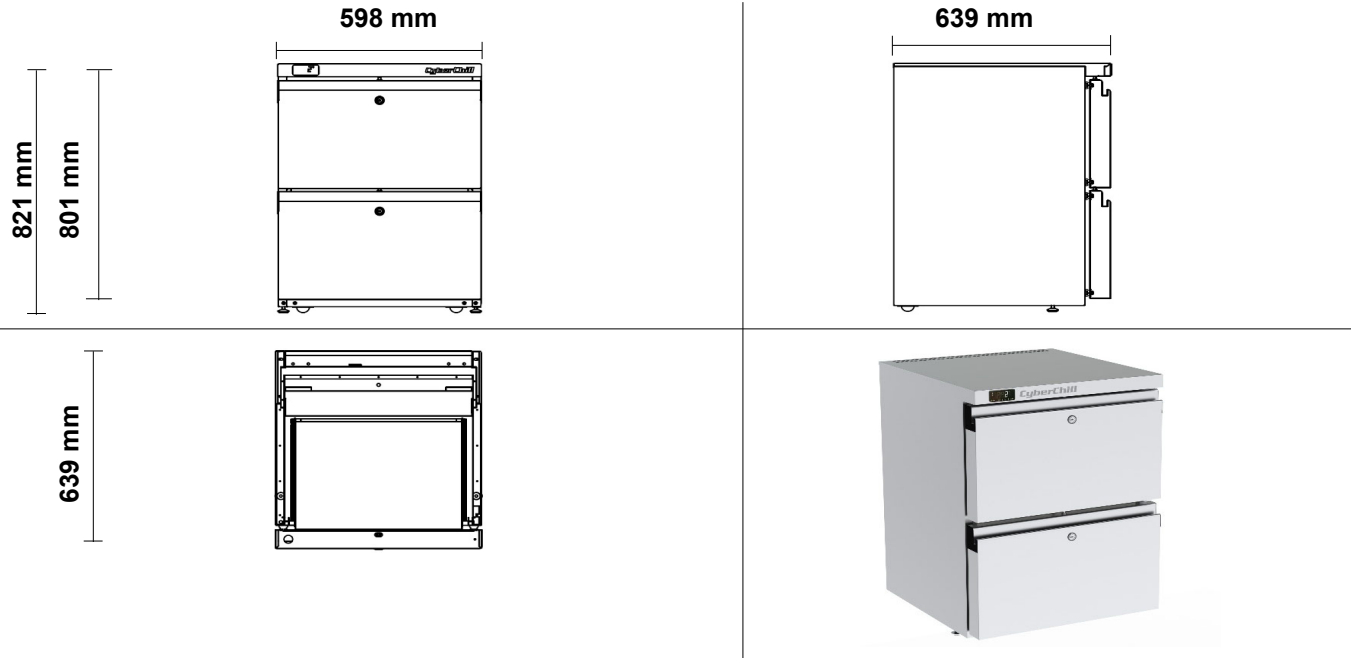

Integral 2-Drawer Under Counter Chiller



Specifications

Refrigeration system	Self-contained, electronically controlled, refrigeration unit		
Refrigerant	R600a	Gas Charge	80 g
Electrical	220-240 Volts a.c. 50 Hz	Amps	1 Amps
Nominal capacity	350 Watts @ -10°C SST		
Drainage	Waste heat vaporiser located in service compartment (no plumbing required)		
Insulation	60mm thick, high density Zero ODP injected polyurethane insulation		
Cabinet body	304 Stainless Steel Interior & Exterior, Galvanised Steel Back & Base		
Cabinet temperature range	-2°C to +4°C up to 32°C ambient		
kWh/24hr	3.19 kWh	Star Rating	tbc
Cabinet internal volume	77 litres	Net usable GN volume	tbc
Weight	70 kg	dBA	52
Worktop	Removable 40mm stainless steel worktop		
Internal Door / Drawer GN Capacity	; 2 x Drawer: Accepts 200mm D pans)		
Doors / Drawer Configuration	; 1 x SS Lockable Bank of Half Drawers		
Shelves	2 x shelves & adjustable tray slides per door	Total = 0	
Options	Banks of 2/3 Drawers, Glass Doors, Stacking Kits, Legs / Castors		
Cabinet dimensions	External	Internal	
Width	598 mm	495 mm	
Depth	639 mm	379 mm	
Height	801 mm (excl. legs, castors & worktop)		646 mm

Note: Rear mounted compressor. Please ensure cabinet is removable for maintenance. Unit requires 50mm rear ventilation as well as 20mm top and side ventilation.