

# SPECIFICATIONS

## HLRU2-SS/SS-GGD

### Retro Freezer/Chiller

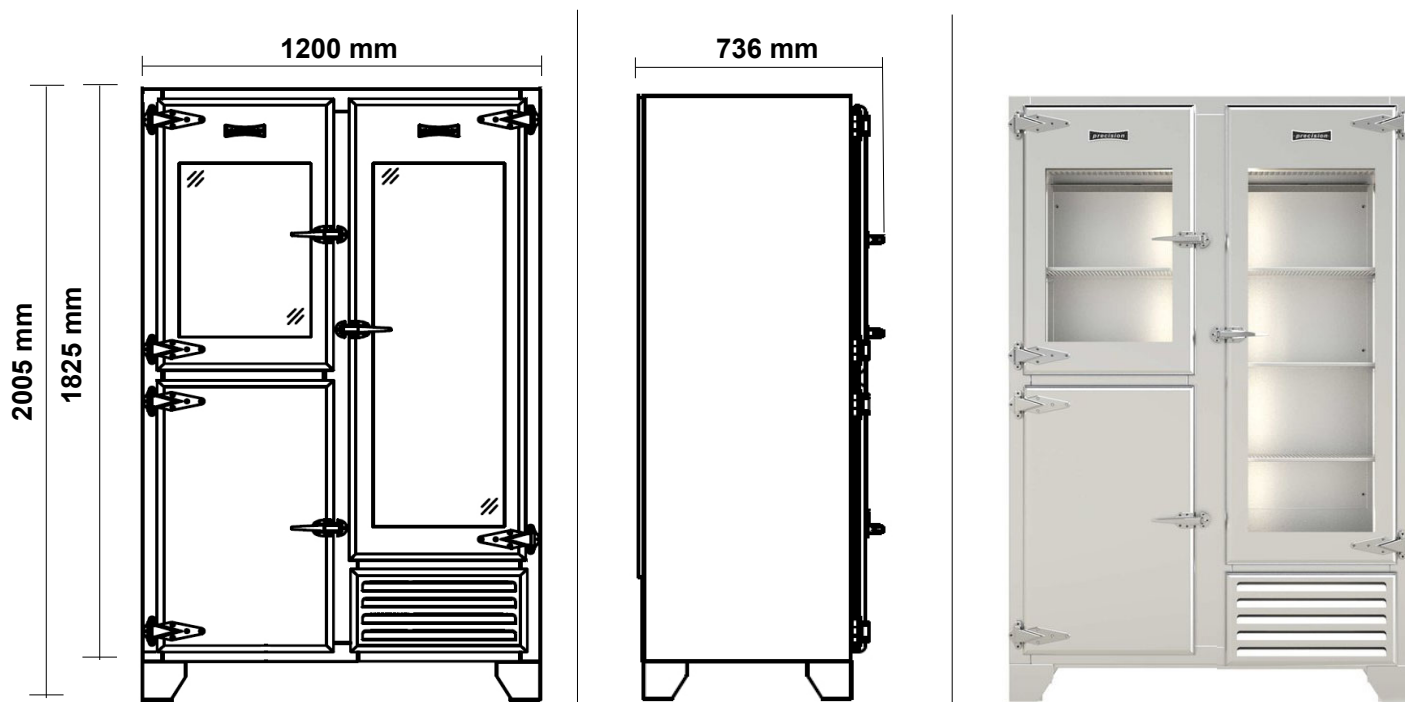

### Specifications

Refrigeration system	Self-contained, bottom mounted, electronically controlled, refrigeration unit		
Refrigerant	R290	Gas Charge	126 (F) / 90 (C)
Electrical	220-240 Volts a.c. 50 Hz	Amps	6.3 Amps
Nominal capacity	250 Watts @ -30°C SST / 650 Watts @ -10°C SST		
Drainage	Waste heat vaporiser located in service compartment (no plumbing required)		
Insulation	60mm thick, high density Zero ODP injected PUR insulation		
Cabinet body	Stainless Steel Exterior & Interior, Galvanised Steel Back & Base		
Cabinet temperature range	+1°C to +4°C up to 40°C ambient		
kWh/24hr	n/a	Star Rating	tbc
Cabinet internal volume	tbc	Net usable GN volume	797 litres
Weight	215 kg	dBA	77
Door Opening	3 x Self-Closing Lockable Door(s)		
Door Configuration	2 x Triple Glazed LowE Argon filled Glass Doors; 1 x Stainless Steel Solid Doors		
Shelves	Stainless steel perforated shelves included		Total = 6
Options	Solid/Glass Doors, Legs/Castors, SS/Painted Exterior, etc.		
Cabinet dimensions	External		
	Width	1200 mm	
	Depth	736 mm	
	Height	1825 mm (excl. legs or castors)	