

SPECIFICATIONS

GCS965-UG

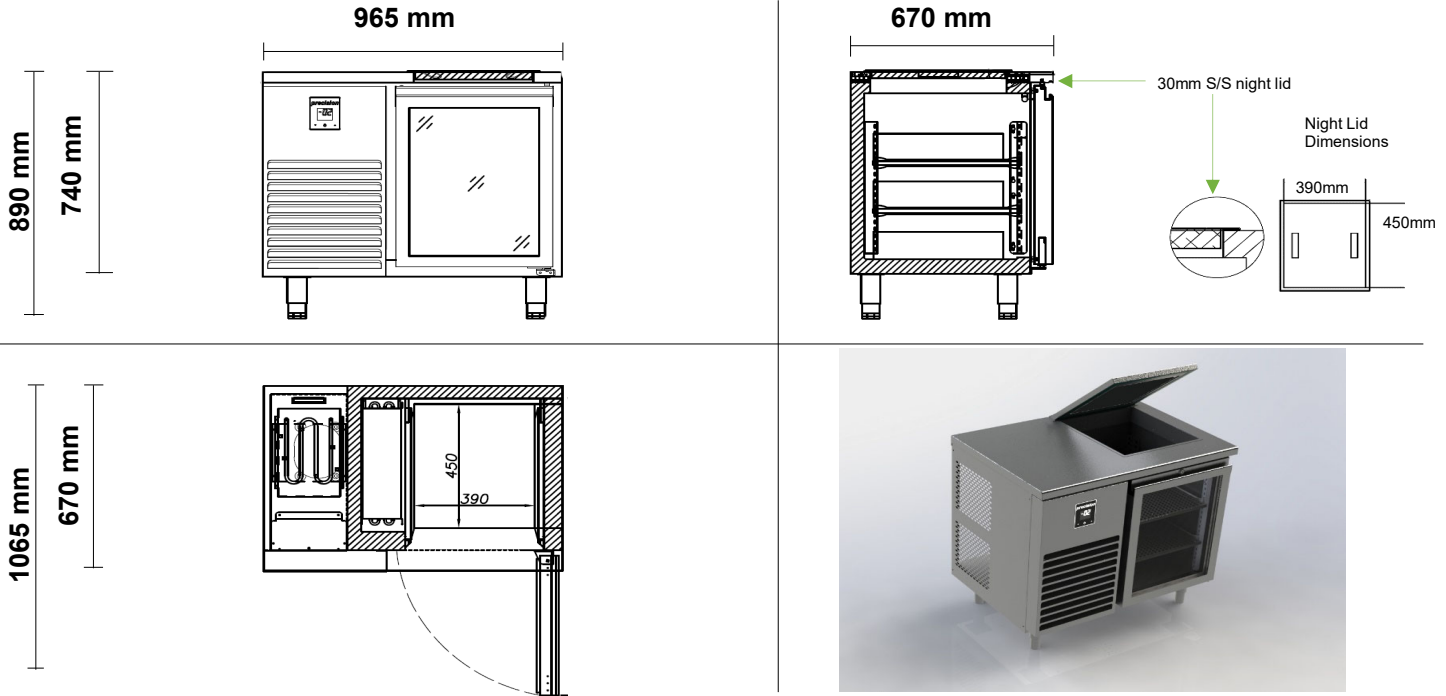

1-Door Glass Chiller (Integral)



Specifications

Refrigeration system	Self-contained, side mounted, electronically controlled, refrigeration unit		
Refrigerant	R290	Gas Charge	80 g
Electrical	220-240 Volts a.c. 50 Hz	Amps	2 Amps
Nominal capacity	412 Watts @ -10°C SST		
Drainage	Waste heat vaporiser located in service compartment (no plumbing required)		
Insulation	60mm thick, high density Zero ODP injected polyurethane insulation		
Cabinet body	304 Stainless Steel Interior & Exterior, Galvanised Steel Back & Base		
Cabinet temperature range	+1°C to +4°C up to 43°C ambient		
kWh/24hr	tbc	Star Rating	tbc
Cabinet internal volume	tbc	Net usable GN volume	n/a
Weight	120 kg	dB(A)	tbc
Worktop	Stainless steel worktop, 1 x Well(s) to suit 3 x wire baskets (355 x 430 x 100mm) fitted with lift-off SS lid		
Internal Door / Drawer GN Capacity	1 x Door: Accepts wire glass baskets (355mm x 430mm)		
Doors / Drawer Configuration	1 x Lockable Triple Glazed LowE Argon filled glass door(s);		
Shelves	2 x shelves & adjustable tray slides per door	Total = 2	
Options	Solid Door, Spring Action shelving		
Cabinet dimensions		External	Internal
	Width	965 mm	445 mm
	Depth	670 mm	550 mm
	Height	700 mm (excl. legs, castors & worktop)	600 mm