

SPECIFICATIONS

CBF200-G

CyberChill
precision
refrigeration

1-dr Under Counter Chiller

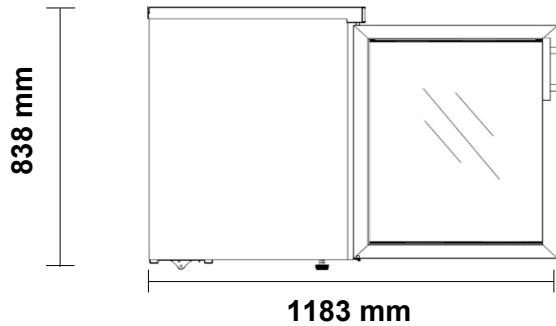
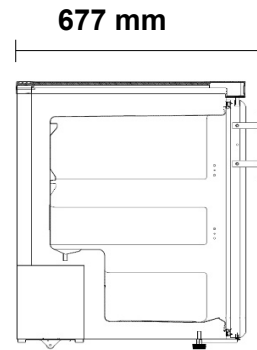
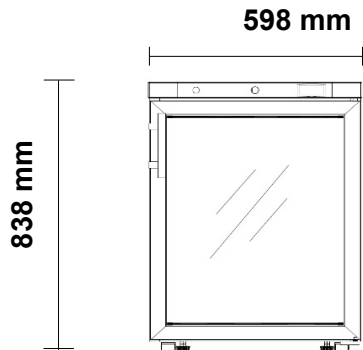

Specifications

Refrigeration system	Self-contained, bottom mounted, electronically controlled, refrigeration unit		
Refrigerant	R290		
Electrical	220-240 Volts a.c. 50 Hz	Amps	tbc
Nominal capacity	500 Watts @ -5°C SST		
Drainage	Waste heat vaporiser located in service compartment (no plumbing required)		
Cabinet body	Stainless Steel Exterior & White Interior		
Cabinet temperature range	-18°C to -22°C at 32°C Ambient		
Cabinet internal volume	200 litres		
Weight	48 kg		
Door Opening	1 x Self-Closing Lockable Door(s)		
Shelves	3 x shelves per cabinet	Total = 3	
Options	Solid Door, LH/RH Hinged Door		
Cabinet dimensions	External		
	Width	598 mm	
	Depth	677 mm	
	Height	838 mm (excl. legs or castors)	