

# SPECIFICATIONS

## CB200-G

### 1-dr Under Counter Chiller

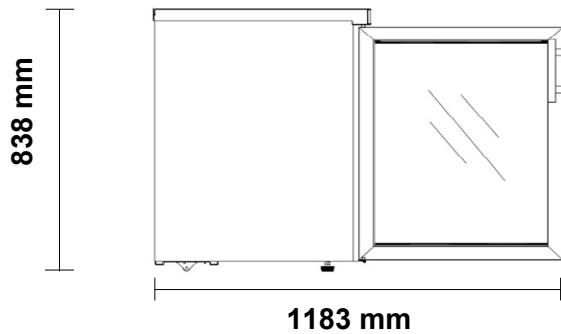
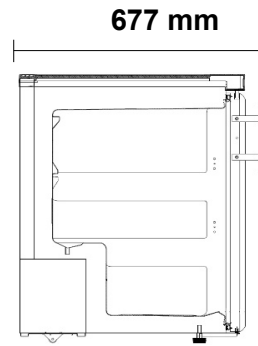
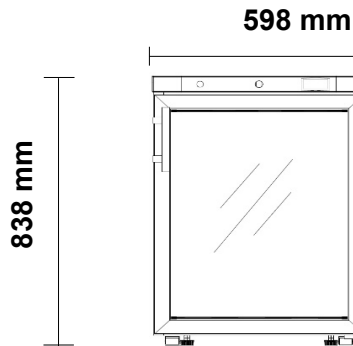

### Specifications

Refrigeration system	Self-contained, bottom mounted, electronically controlled, refrigeration unit		
Refrigerant	R600a		
Electrical	220-240 Volts a.c. 50 Hz	Amps	tbc
Nominal capacity	n/a		
Drainage	Waste heat vaporiser located in service compartment (no plumbing required)		
Cabinet body	Stainless Steel Exterior & White Interior		
Cabinet temperature range	+2°C to +8°C at 32°C Ambient		
Cabinet internal volume	200 litres		
Weight	46 kg		
Door Opening	1 x Double LowE Safety Glass Door		
Shelves	3 x shelves per cabinet	Total = 3	
Options	Solid Door, LH/RH Hinged Door		
Cabinet dimensions	External		
	Width	598 mm	
	Depth	677 mm	
	Height	838 mm (excl. legs or castors)	